

18th launch for Intelsat

Arianespace's fourth launch of the year will orbit the Intelsat 901 communications satellites for the International Telecommunications Satellite Organization, Intelsat. Kicking off the series 9 family of satellites, this launch confirms Intelsat's confidence in Arianespace, chosen to launch six out of seven new-generation satellites. The Intelsat 9 series is a powerful driver in the international operator's development strategy.

Intelsat 901 will be the 18th Intelsat satellite launched to date by Ariane. Built by Space Systems/Loral in Palo Alto, California, it will be positioned at 342 degrees East. It joins the Intelsat fleet of satellites providing telecommunications and television services for the Americas, Europe, North Africa and the Near East.

Five more Intelsat satellites are scheduled for launch by Arianespace, including two this year.

This launch reflects Arianespace's position as the benchmark launch system for all operators, public or private, national or international.

For Flight 141, Arianespace will use an Ariane 44L, the version fitted with four liquid-propellant strap-on boosters.

- 1 - ARIANESPACE Flight 141 mission.
- 2 - Range operations :
ARIANE 44L - INTELSAT 901.
- 3 - Countdown and Flight events.
- 4 - Flight 141 trajectory.
- 5 - The ARIANE 44L launch vehicle.
- 6 - The INTELSAT 901 satellite.

Annexes

- 1 - Flight 141 key personnel.
- 2 - Launch environment conditions.
- 3 - Synchronized sequence.
- 4 - ARIANESPACE orderbook.
- 5 - ARIANESPACE, ESA and CNES.

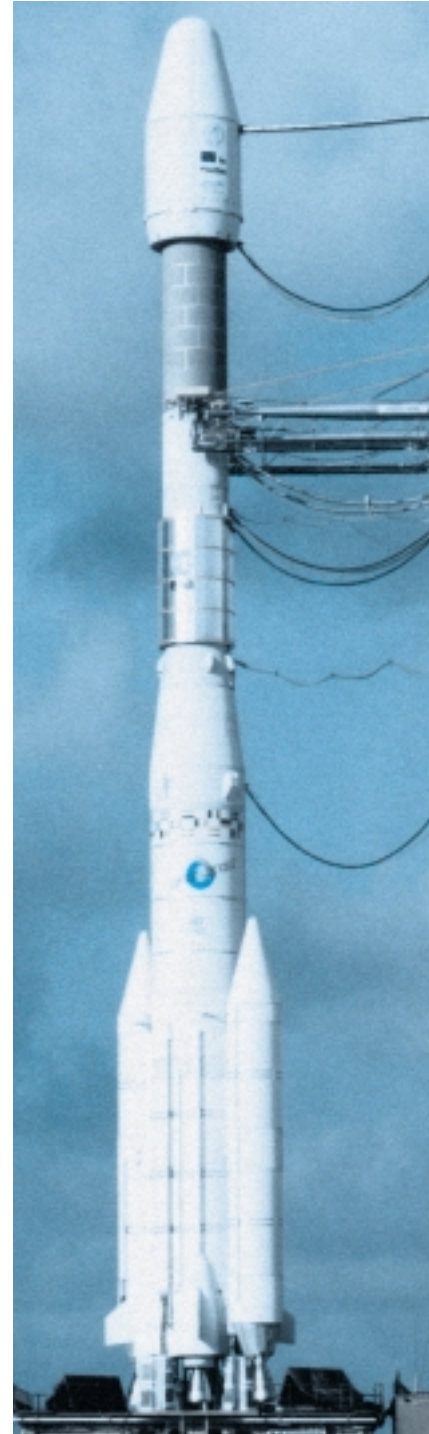

1 - ARIANESPACE Flight 141 MISSION

The 141st Ariane launch (Flight 141) is scheduled to place the INTELSAT 901 satellite into a geostationary transfer orbit using an ARIANE 44L launch vehicle equipped with four liquid strap-on boosters (PAL). This will be the 104th Ariane 4 launch and the 32nd in the ARIANE 44L configuration.

It will be launched from the Ariane launch complex n°2 (ELA2), in KOUROU, French Guiana. The launch vehicle performance requirement is 4 768 kg (10 489 lb) of which 4 723 kg (10 410 lb) represent the mass of the spacecraft to be separated on the injection orbit.

INJECTION ORBIT

Perigee	225 km
Altitude Apogee	35 945 km at injection
Inclination	7° degrees

The ARIANE 44L launcher liftoff for Flight 141 is scheduled on the morning of June 8, 2001 as early as possible within the following launch window :

LAUNCH OPPORTUNITY

GMT	Paris time	Washington time	Kourou time
From 06:44 am	08:44 am	02:44 am	03:44 am
to 07:44 am	09:44 am	03:44 am	04:44 am
on June 8, 2001	June 8, 2001	June 8, 2001	June 8, 2001

Ariane payload configuration

The **INTELSAT 901 satellite** was built by SPACE SYSTEMS/LORAL in Palo Alto (California), for the international operator INTELSAT.

Orbital position: 342° East

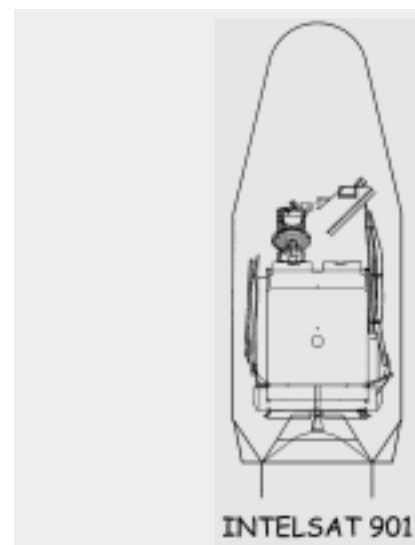

2. RANGE OPERATIONS CAMPAIGN : ARIANE 44L – INTELSAT 901

The actual work for satellite range operations lasts 20 working days for INTELSAT 901 from its arrival in Kourou (before encapsulation).
The ARIANE 44L preparation campaign lasts 25 working days.

SATELLITE AND LAUNCH VEHICLE CAMPAIGN CALENDAR

<i>Ariane activities</i>	<i>Dates</i>	<i>Satellite activities</i>
<i>Campaign start review</i>	<i>April 26, 2001</i>	
<i>First stage erection</i>	<i>April 26, 2001</i>	
<i>Second stage erection</i>	<i>April 27, 2001</i>	
	<i>May 2, 2001</i>	<i>INTELSAT 901 arrival in Kourou and beginning of its preparation in S1B building.</i>
<i>Third stage erection</i>	<i>May 7, 2001</i>	
<i>Liquid strap-on boosters erection</i>	<i>May 2-7, 2001</i>	
	<i>May 18, 2001</i>	<i>INTELSAT 901 transfer from S1B to S3B building.</i>
<i>Roll-out to launch pad</i>	<i>May 18, 2001</i>	
	<i>May 21, 2001</i>	<i>Beginning of INTELSAT 901 filling operations.</i>
<i>D-7 Monday, May 28, 2001</i>	<i>Start of combined operations</i>	
<i>D-6 Tuesday, May 29</i>	<i>Satellite encapsulation operations.</i>	
<i>D-5 Wednesday, May 30</i>	<i>Satellite composite transfer to the launch pad.</i>	
<i>D-4 Thursday, May 31</i>	<i>Satellite composite mating onto launcher and overall checks.</i>	
<i>D-3 Friday, June 1</i>	<i>Launch Rehearsal</i>	
<i>D-2 Tuesday, June 5</i>	<i>Launch Readiness Review (RAL) and launcher arming.</i>	
<i>D-1 Wednesday, June 6</i>	<i>Filling of 1st stage, and 2nd stage, and liquid boosters with UH 25 and N2O4.</i>	
<i>D-0 Thursday, June 7</i>	<i>Launch Countdown including 3rd stage filling with liquid oxygen and liquid hydrogen.</i>	
<i>H-0 Friday, June 8</i>		

3. LAUNCH COUNTDOWN AND FLIGHT EVENTS :

The final launch countdown runs through all the final launcher and satellites related operations. It configures the vehicle and its payload for ignition of the first stage and PAL engines at the selected launch time, as soon as possible within the launch window authorized by the spacecraft.

A synchronized sequence (see Appendix 3), controlled by the Ariane ground check-out computers, starts at H0 - 6mn and concludes the countdown.

Should a hold in the countdown delay the H0 time beyond the launch window, the launch is postponed to (in days) : D + 1 or D + 2 (or later) depending on the source of the problem and the time to resolve it.

Time	Events
- 12h 30 mn 00 s	Start of final countdown.
- 5 h 35 mn 00 s	Start of gantry withdrawal.
- 3 h 35 mn 00 s	Start of the 3rd stage filling operations with liquid hydrogen and liquid oxygen.
- 1 h 5 mn 00 s	Activation of launcher telemetry, radar transponders, telecommand.
- 6 mn 00 s	"Green status for all systems" to authorize : start of synchronized launch sequence
- 3 mn 40 s	Spacecraft switched to on-board power (latest time).
- 1 mn 00 s	Launcher equipment switched to on-board batteries.
- 09 s	Inertial platform released.
- 05 s	Release command to cryogenic arms retraction system.
H0	Ignition of first stage and liquid strap-on boosters engines
+ 4,4 s	Lift-off.
+ 16 s	End of vertical ascent phase of pitch motion (10 s duration).
+ 2 mn 30 s	Liquid strap-on booster jettison.
+ 3 mn 31 s	First stage separation.
+ 3 mn 34 s	Second stage ignition.
+ 4 mn 24 s	Fairing jettison.
+ 5 mn 43 s	Second stage separation.
+ 5 mn 48 s	Third stage ignition.
+ 6 mn 30 s	Launcher acquired by Natal station.
+ 12 mn 30 s	Launcher acquired by Ascension Island station.
+ 17 mn 30 s	Launcher acquired by Libreville station.
+ 18 mn 49 s	Third stage shutdown sequence.
+ 20 mn 56 s	INTELSAT 901 separation.
+ 22 mn 13 s	Start of the third stage avoidance maneuver.
+ 24 mn 10 s	End of ARIANESPACE Flight 141 mission.

4. Flight 141 TRAJECTORY :

The launcher ascends vertically from lift-off to H0+16 sec. During a period of 10 sec. after this vertical ascent, the launch vehicle tilts in the pitch plane defined by the trajectory and pre-calculated by the on-board computer.

The vehicle's attitude is commanded by a predetermined law. The guidance phase is initiated 10 sec. after ignition of the 2nd stage. The attitude law in the pitch-and-yaw plane is optimized in order to minimize the 3rd stage propulsion time necessary to reach the target orbit with a performance margin of about 164 kg (360 lb). This ensures reaching this orbit with a probability of about 99% before the exhaustion of third stage propellant.

The roll law is applied so as to improve the launcher/ground station radio link budget.

TYPICAL TRAJECTORY FOR STANDARD GEOSTATIONARY TRANSFER ORBIT AND GROUND STATION VISIBILITY

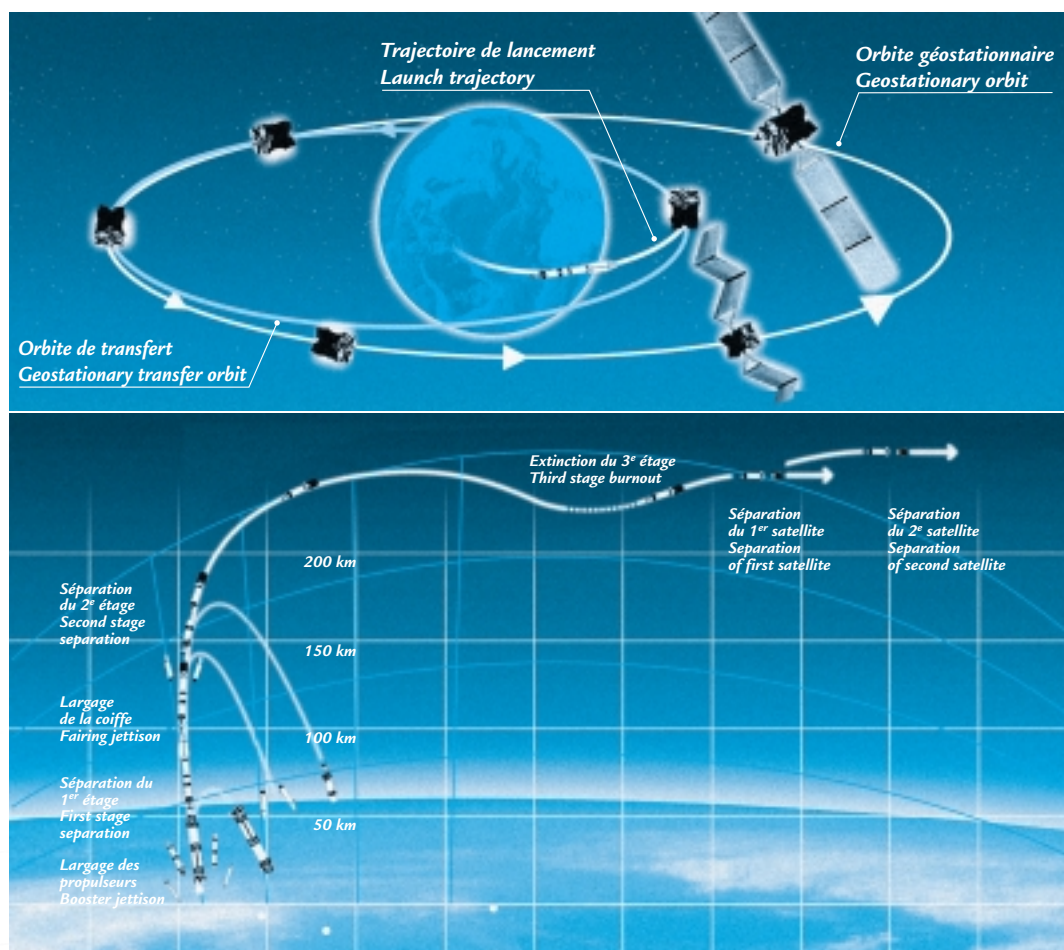

5. THE LAUNCH VEHICLE :

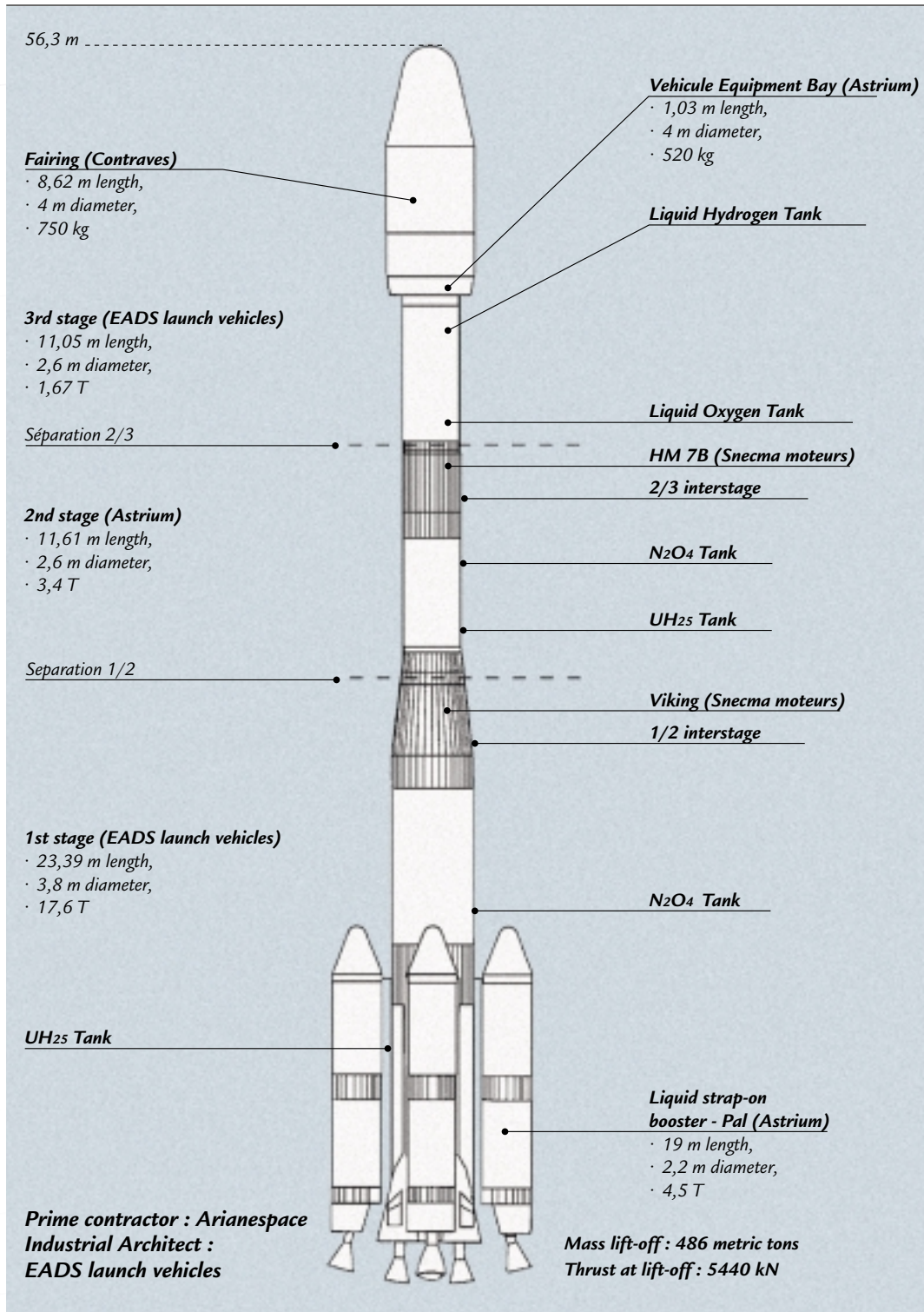

6. THE INTELSAT 901 SATELLITE

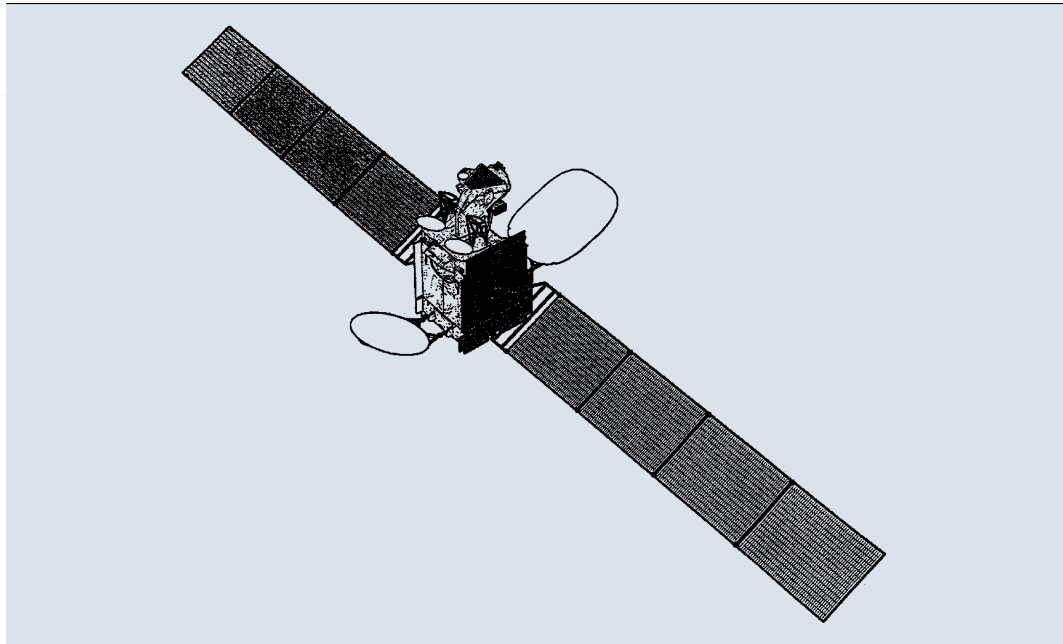

Customer	INTELSAT	
Prime contractor	SPACE SYSTEMS/LORAL in Palo Alto (California)	
Mission	Telecommunications and Television	
Mass	Total mass (at lift-off)	4 723 kg (10 410 lb)
Dry mass		1 972 kg (4 338 lb)
Stabilization	3 axis	
Dimensions	2,80 m x 3,50 m x 5,56 m	
Span in orbit	31 m	
Platform	FS1300 Extended	
Payload	44 C Band transponders 12 Ku Band transponders	
On-board power	10 kW (beginning of life)	
Life time	13 years	
Orbital location	342° East	
Coverage area	Global with beams over North and South America, Europe, Africa and Middle East	

Press Contact for INTELSAT

Susan GORDON
 Corporate Communications Director
 Tél. : +1 202 944 6890 - Fax : +1 202 944 7890
 e-mail : susan.gordon@intelsat.com

ANNEX 1 - ARIANESPACE Flight 141 KEY PERSONNEL

In charge of the launch campaign

<i>Mission Director</i>	(CM)	<i>Philippe ROLLAND</i>	ARIANESPACE
-------------------------	------	-------------------------	-------------

In charge of the launch service contracts

<i>INTELSAT 901 Mission Manager and ARIANE Payload Manager</i>	(RCUA)	<i>Steve HALL</i>	ARIANESPACE
<i>Deputy Mission Manager</i>	(RCUA/A)	<i>Michael CALLARI</i>	ARIANESPACE

In charge of INTELSAT 901 satellite

<i>Satellite Mission Director</i>	(DMS)	<i>Terry EDWARDS</i>	INTELSAT
<i>Satellite Project Manager</i>	(CPS)	<i>Grant GOULD</i>	SPACE SYSTEMS/LORAL
<i>Satellite Preparation Manager</i>	(RPS)	<i>Roy CARLISLE</i>	SPACE SYSTEMS/LORAL

In charge of the launch vehicle

<i>Launch Site Operations Manager</i>	(COEL)	<i>Francis PELLACOEUR</i>	ARIANESPACE
<i>Ariane Production Project Manager</i>	(CPAP)	<i>Martine MOYER</i>	ARIANESPACE

In charge of the Guiana Space Center (CSG)

<i>Range Operations Manager</i>	(DDO)	<i>Michel DEBRAINE</i>	CNES/CSG
<i>Flight Safety Officer</i>	(RSV)	<i>Stanislas BLANC</i>	CNES/CSG

ANNEX 2 - LAUNCH ENVIRONMENT CONDITIONS

The allowable weather conditions for gantry withdrawal depend on the Ariane stage pressurization values. Wind speed has to be below 17 m/s. Acceptable wind speed limits at liftoff range from between 9 m/s to 14 m/s according to the wind direction. The most critical is a northerly wind. For safety reasons, the wind speed on the ground (at Kourou) and at a high altitude (between 10,000 and 20,000 m) also is taken into account.

ANNEX 3 - SYNCHRONIZED SEQUENCE

The synchronized sequence starts at H0 -6 min. This sequence is used for final preparation of the launcher, and for checkout operations related to switchover to flight configuration. The sequence is fully automatic, and is controlled in parallel, up to H0-5 sec., by two computers in the Ariane Launch Center (CDL). All resources used for launch are synchronized on a common countdown sequence.

One computer configures fluids and propellants for flight and performs associated checks. The other computer executes final preparation of the electrical systems (initiation of flight program, start-up of servomotors, switchover from ground power to flight batteries, etc.) and corresponding checkout operations.

After H0 - 5 s. and retraction of the cryogenic arms retraction from the launcher, a majority logic sequencer delivers the main timing pulses for :

- first stage & liquid booster engine ignition (H0) ;
- engine parameter checkout (conducted in parallel by the two computers, starting at H0 + 2.8 s.) ;
- opening of the launch table clamps (releasing the launch vehicle between H0 + 4. 1s. and H0 + 4.6 s.) as soon as engine parameters are judged as nominal by one of the computers.

Any hold in the synchronized sequence before H0 - 5 s. automatically resets the launcher to the H0 - 6 min. configuration

ANNEX 4 - ARIANESPACE ORDER BOOK

To date 185 satellites and 38 auxiliary payloads have been launched by Arianespace
 Out of the 234 launch services contracted since 1981 by Arianespace and before Flight 141, 38 satellites and 9 ATV launches remain to be launched.

Europe 12 satellites

Artemis
Astra 1K, X, 3A
Atlantic Bird 2
e-Bird
Envisat-1/PPF
Hot Bird 6
MSG-1 & 2
Spot 5
Stentor

+ 9 ATV launches

International organizations 10 satellites

Ameristar (Worldspace)
Intelsat 901, 902, 904, 905, 906, 907
New Skies Satellites 6 & 7
Stellat

Middle-East and Africa 1 satellite

Amos 2 (Israel)

Americas 6 satellites

Anik F2 (Canada)
Directv-4S (USA)
GE TBD (USA)
Loralsat 3 (USA)
Wild Blue 1 & 2 (USA)

Asia 9 satellites

B-SAT 2b (Japan)
Insat 3C, 3A & 3E (India)
JCSAT 8 (Japan)
L-Star A & B (Thailand/Laos)
N-STAR C (Japan)
Optus C1 (Australia)

International

- Intelsat
- New Skies
- Stellat
- Worldspace

Europe

- ESA
- Eumetsat
- Eutelsat
- France
- Luxemburg

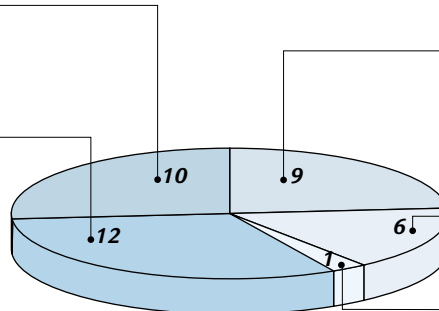

Asia

- Australia
- India
- Japan
- Thailand/Laos

Americas

- Canada
- USA

Middle East and Africa

- Israel

APPENDIX 5 - ARIANESPACE, its relations with ESA et CNES

FROM A PRODUCTION BASE IN EUROPE, ARIANESPACE, A PRIVATE COMPANY, SERVES CUSTOMERS ALL OVER THE WORLD. Arianespace is the world's first commercial space transportation company, created in 1980 by 36 leading European aerospace and electronics corporations, 13 major banks and the French space agency CNES (Centre National d'Etudes Spatiales).

Arianespace is a European venture--, the direct result of the participating nation's commitment to bringing the Ariane family of launch vehicles from the drawing board to the launch pad. To do so, they turned to the European Space Agency (ESA) and mobilized the scientific and technological expertise of CNES.

The shareholder partners in Arianespace represent the scientific, technical, financial and political capabilities of 12 countries : Belgium, Denmark, Germany, France, Great Britain, Ireland, Italy, Netherlands, Norway, Spain, Switzerland and Sweden.

In order to meet the market needs, Arianespace is present throughout the world : in Europe, with its head office located near Paris, France at Evry, in North America with its subsidiary in Washington D.C. and in the Pacific Region, with its representative offices in Tokyo, Japan, and in Singapore.

Arianespace employs a staff of 380. Share capital totals FF 2,088 million.

As a space transportation company, Arianespace :

- m markets launch services to customers throughout the world ;
- m finances and supervises the construction of Ariane expendable launch vehicles ;
- m conducts launches from Europe's Spaceport in Kourou in French Guiana ;
- m insures customers for launch risks.

Personalized reliable service forms an integral part of Arianespace's launch package. It includes the assignment of a permanent team of experts to each mission for the full launch campaign. Our customers appreciate the time and cost savings made possible by our efficiency and flexibility.

Most of the world's commercial satellite operators have contracted to launch at least one payload with Arianespace. This record is the result of our company's realistic cost-effective approach to getting satellites into orbit.

RELATIONS BETWEEN ESA, CNES AND ARIANESPACE

Development of the Ariane launcher was undertaken by the European Space Agency in 1973. ESA assumed overall direction of the ARIANE 1 development program, delegating the technical direction and financial management to CNES. The ARIANE 1 launcher was declared qualified and operational in January 1982. At the end of the development phase which included four launchers, ESA started the production of five further ARIANE 1 launchers. This program, known as the "promotion series", was carried out with a management arrangement similar to that for the ARIANE 1 development program

In January 1980 ESA decided to entrust the commercialization, production and launch of operational launchers to a private-law industrial structure, in the form of ARIANESPACE, placing at its disposal the facilities, equipment and tooling needed to build and launch the ARIANE vehicles.

Ariane follow-on development programs have been undertaken by ESA since 1980. They include a program for developing uprated versions of the launcher : Ariane 2 and Ariane 3 (qualified in August 1984); the program for building a second ARIANE launch site (ELA 2) (validated in August 1985); the Ariane 4 launcher development program (qualified on June 15th, 1988); and the preparatory and development program of the Ariane 5 launcher and its new ELA 3 launch facility. All these programs are run under the overall direction of ESA, which has appointed CNES as prime contractor.

In general, as soon as an uprated version of the launcher has been qualified, ESA makes the results of the development program together with the corresponding production and launch facilities available to ARIANESPACE.

ESA is responsible (as design authority) for development work on the Ariane launchers. The Agency owns all the assets produced under these development programs. It entrusts technical direction and financial management of the development work to CNES, which writes the program specifications and places the industrial contracts on its behalf. The Agency retains the role of monitoring the work and reporting to the participating States.

Since Flight 9 Arianespace has been responsible for building and launching the operational Ariane launchers (as production authority), and for industrial production management, for placing the launcher manufacturing contracts, initiating procurements, marketing and providing Ariane launch services, and directing launch operations.

USE OF THE GUIANA SPACE CENTER

The "Centre Spatial Guyanais" (CSG), CNES's launch base near Kourou, has all the equipment needed for launching spacecraft : radar tracking stations, telemetry receiving stations, a meteorology station, a telecommand station, safety facilities, etc...

It became operational in 1968 for the purpose of the French National Space Program.

ESA built its own launch facilities, the ELA 1 and ELA 2 complexes (for Ariane 4) and ELA 3 (for Ariane 5) and the EPCU payload preparation complex. These facilities comprise Europe's Spaceport. The use of these facilities requires, CSG's technical and operational resources, especially during launch operations. The French Government has granted ESA the right to use the CSG for its space programs. In return, ESA shares in the costs of operating the CSG.

Arianespace directly covers the costs of use, maintenance and upgrading of the Ariane launch sites and the payload preparation complex.