

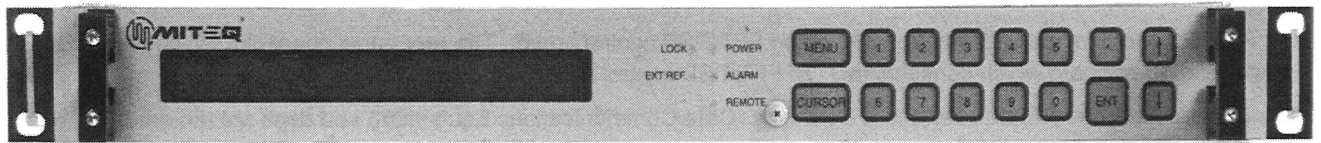

## L-BAND BEACON RECEIVER



### MODEL NUMBER SUPPLIED

BR-L

### OPTIONS SUPPLIED

Option 17C: RS232 Remote Interface

---

100 Davids Drive  
Hauppauge, New York 11788-2034  
Tel: 631 436 7400  
Fax: 631 436 7431  
[www.miteq.com](http://www.miteq.com)

## DOCUMENTATION REVISIONS

The purpose of this section is to chronicle any and all changes made in this manual, in regards to both technical information concerning this piece of equipment, and the actual format/function of this document.

9/5/08: INITIAL RELEASE (preliminary)

10/20/08: PRELIMINARY RELEASE #2  
ADDED PG.2 TO BLOCK 182945

11/4/08: INITIAL RELEASE  
REPAGED MANUAL PER ANY CHANGES MADE  
PG.25 - SWITCHED FIGURES 5-16 AND 5-17 AROUND  
PG.27 - SENTENCE ADDED FOR OPTION 17C CONFIGURATION  
PG.27 - SECOND 10-BIT SEQUENCE TYPE LISTED  
PG.71 - ADDED RF MODULE SPECIFICATIONS

2/9/09: REV.A TO REV.B

PG.4 - CHANGE RS232 (J6) PARAGRAPH FROM

For RS232 operation, install jumper on J16 and RS232 cable between J1 and rear panel.

TO

For RS232 operation, install jumper on J16 of the FFT/DSP control board. The rear panel connector plugs into an RS232 interface adapter board which connects to J1 of FFT/DSP control board.

The Beacon Receiver RS232 interface is DCE type (Data Communications Equipment) and does not require a null modem when connecting up to the M&C computer.

3/16/09: REV.B TO REV.C (prelim)

PG.3 - ADDED **CLOCK SIGNAL TO J10 TABLE**

PG.6 - ADDED **ZERO SETTING TO TABLE 2-2**

PG.8 - CHANGED **20, 50, 100 SECONDS TO 15, 30, 60 SECONDS IN TABLE 2-6**

PG.8 - ADDED **120, 300, 600 SECONDS TO TABLE 2-6**

PG.14 - CHANGED FREQUENCIES TO Hz IN **FIGURE 5-1**

CHANGED **CARRIER TO NOISE MENU TO VIDEO BANDWIDTH MENU AND MOVED TO PAGE 19;**

RENUMBERED **FIGURES 5-5 THROUGH 5-9 AS RESULT**

PG.17 - CHANGED **LEVEL TO LVL IN FIGURE 5-6**

PG.18 - REMOVED **HOLDTIME FROM FIGURE 5-8**

PG.20 - REPLACED **VIDEO BW WITH VOUT IN FIGURE 5-10**

PG.21 - REPLACED **VIDEO BW WITH VOUT**

PG.25 - CHANGED **Ethernet password TO chassis temperature in degree C IN RECEIVER TITLE MENU**

PG.25 - REVISED **FIGURE 5-18**

PG.26 - CHANGED **VERSION NUMBER FROM V01.00 TO V2.000 IN FIGURE 5-20**

PG.31 - ADDED **000 PARAMETER TO AQR COMMAND CODE**

PG.33 - CHANGED **FOUR TO SIX DIGIT IN DEL COMMAND CODE**

PG.33 - CHANGED **NSU TO Beacon Receiver IN EAD COMMAND CODE**

PG.34 - CHANGED **7 TO 10 ASCII CHARACTERS AND kHz TO Hz IN FRQ COMMAND CODE**

PG.34 - CHANGED **THREE TO FOUR DIGIT IN HOL COMMAND CODE**

PG.34 - CHANGED **HOLDTIME PARAMETERS (SEE PG.8 CHANGES)**

PG.35 - CHANGED **64 TO 99 IN LOG COMMAND CODE**

PG.36 - CHANGED **7 TO 10 ASCII CHARACTERS AND kHz TO Hz**

PG.37 - ADDED **000 PARAMETER TO AQR**

PG.38 - ADDED **+ AND - SIGNS TO SLP**

PG.38 - CHANGED **HOLDTIME PARAMETERS (SEE PG.8 & PG 34 CHANGES)**

PG.38 - CHANGED **FIVE TO FOUR DIGIT IN RFG**

PG.40 - **x CHANGED TO 16 IN MOD COMMAND CODE**

PG.40 - ADDED **at the Manual AGC setting TO THE MVL COMMAND CODE**

PG.41 - CHANGED **4 TO 6 AND kHz TO Hz IN OFF COMMAND CODE**

PG.41 - CHANGED **SIX TO SEVEN CHARACTERS IN OFF COMMAND CODE**

PG.41 - CHANGED **FOUR TO FIVE DIGIT IN OUT COMMAND CODE**

3/16/09: REV.B TO REV.C (CONTINUED)

- PG.44 - REMOVED **Up to AND** CHANGED **allowed TO required** IN **RTL COMMAND CODE**
- PG.42 - CHANGED **SIX TO SEVEN CHARACTER** IN **PWR COMMAND CODE**
- PG.42 - CHANGED **FIVE TO SIX CHARACTER** IN **REF COMMAND CODE**
- PG.42 - CHANGED **SIX TO FIVE DIGIT** IN **REF COMMAND CODE**
- PG.45 - CHANGED **INPUT FREQUENCY INDICATOR FROM 7 TO 10 DIGIT**
- PG.45 - ADDED **000 PARAMETER TO AQR**
- PG.46 - ADDED **+ AND - SIGNS TO SLP**
- PG.47 - CHANGED **HOLDTIME PARAMETERS (SEE PG.8 AND PG.34 CHANGES)**
- PG.48 - ADDED **+ AND - SIGNS TO SLP COMMAND CODE**
- PG.49 - CHANGED **TWO TO FOUR DIGIT** IN **TMP COMMAND CODE**
- PG.58 - NEW **FIGURE 5-23 SCREEN SHOT**
- PG.59 - NEW **FIGURE 5-24 SCREEN SHOT**
- PG.61 - CHANGED **NSU TO BR-L** IN **SET CLOCK**
- PG.62 - NEW **FIGURE 5-27 SCREEN SHOT**
- PG.63 - NEW **FIGURE 5-28 SCREEN SHOT**
- PG.67 - REWROTE **STEP 1 OF SET UP GUIDE**
- PG.67 - REMOVED **and hold time 10 sec. FROM STEP 6**
- PG.67 - CHANGED **C/N TO VIDEO BANDWIDTH AND ADDED Set holdtime AND Set video bandwidth TO STEP 7**
- GENERAL - SYSTEM NOW USING **V2.000 SOFTWARE**

7/17/09: REV.C (prelim) TO REV.C (revised)

- PG.36 - ADDED **CODES 34 TO 43**

7/29/09: REV.C (revised) TO REV.C (final)

- PG.6 - CHANGED **0 = 1 Tuner Bandwidth TO ±0 kHz**
- PG.41 - ADDED **The value of IF Gain... TO MVL SET COMMAND PARAGRAPH**
- PG.41 - ADDED **The value returned will be... TO MVL QUERY COMMAND PARAGRAPH**
- PG.44 - ADDED **NOTE TO RFL COMMAND**
- PG.52 - COMPLETELY REVISED **VER COMMAND UNIT RESPONSE**

10/16/09: REV.C TO REV.D

- PG.11 - ADDED **FREQUENCY COMPATIBILITY CONFIGURATION PROCEDURE**
- PG.14 - CHANGED **FREQUENCY CONVERTER TO BEACON RECEIVER** IN FIRST SENTENCE OF **MAIN**

#### **MENU**

- PG.14 - NEW **FIGURE 5-1. ORIGINAL FIGURE 5-1 NOW 5-2 - FOLLOWING FIGURE NUMBERS BUMPED UP**
- PG.15 - **TEST ALARM** CHANGED FROM **INACTIVE TO OFF** IN **FIGURE 5-3**
- PG.17 - ADDED **RF RANGE METER DESCRIPTIONS**
- PG.18 - REMOVED **GAIN CONTROL** FROM FIRST BULLET IN **IF GAIN CONTROL MODE**
- PG.18 - CHANGED **MANUAL INPUT LEVEL TO IF GAIN** IN FIRST BULLET OF **IF GAIN**
- PG.18 - ADDED **Numeric input is not accepted. TO IN LVL**
- PGS.18-19 - REMOVED **HOLD TIME FROM ACQUISITION MENU**
- PGS.19-20 - REORDERED **VIDEO BW, POWER MEASUREMENT MODE AND HOLD TIME**
- PG.20 - ADDED **Carrier to Noise is an estimate of Carrier to Noise Ratio**
- PG.20 - REPLACED **VIDEO BANDWIDTH BULLET WITH OUTPUT VOLTAGE BULLET** IN **OUTPUT MENU**
- PG.20 - REMOVED **Press "ENT" to assert the sign of the Minimum Voltage. AND Press the "CURSOR" key to highlight the Minimum Voltage field on the display. BULLETS FROM MIN**
- PG.20 - REMOVED **Press "ENT" to assert the sign of the Reference Level Voltage. AND Press the "CURSOR" key to highlight the Reference Level Voltage field on the display. BULLETS FROM REF**
- PG.21 - REMOVED **Press "ENT" to assert the sign of the Maximum Voltage. AND Press the "CURSOR" key to highlight the Maximum Voltage field on the display. BULLETS FROM MAX**
- PG.22 - REMOVED **Press the "CURSOR" key to advance to the Minimum Tracking Voltage Value, Press the "CURSOR" key to advance to the Minimum Tracking Voltage Value and Press the "CURSOR" key to advance to the Minimum Tracking Voltage Value; ALSO ADDED Use the numeric data entry keys to display the IF Gain value**
- PG.23 - REMOVED **(half duplex) FROM RS485 AND (full duplex) FROM RS422** IN **BUS**
- PG.24 - ADDED **Static or Dynamic IP Address (DHCP) BULLET**

10/16/09: REV.C TO REV.D (continued)

PG.24 - NEW **FIGURE 5-15** (COMBINING DYNAMIC IP ADDRESS WITH SUBNET MASK)

PG.24 - NEW **FIGURE 5-16** (COMBINING IP GATEWAY WITH PASSWORD); REMOVED ORIGINAL **FIGURE**

**5-16** (PASSWORD)

PGS.24-25 - NEW BULLETS FOR **FIGURES 5-15 AND 5-16**

PG.25 - NEW **FIGURE 5-17** READOUT

PG.26 - REWROTE **FIGURE 5-20**

PG.26 - ADDED **BULLET**

PG.29 - ADDED **BWC** COMMAND

PG.34 - CHANGED \* TO \*\*\*\*\* FOR **I, G AND S** INDICATORS AND ADDED **00000000000** TO EACH IN

**EAD** COMMAND

PG.35 - ADDED **BACKWARD COMPATIBILITY** PARAGRAPH TO **FRQ** COMMAND, AND CREATED

**STANDARD MODE** AND **BACKWARD COMPATIBILITY MODE** SUBSECTIONS

PG.39 - ADDED **STANDARD MODE** AND **BACKWARD COMPATIBILITY MODE** COMMAND SEQUENCES TO

**MEM** COMMAND

PG.45 - ADDED **STANDARD MODE** AND **BACKWARD COMPATIBILITY MODE** COMMAND SEQUENCES TO

**OFF** COMMAND

PG.47 - IN **RFL** COMMAND, ADDED **The detectable limit is -60.0 dBm.**

PG.47 - IN **RFL** COMMAND, CHANGED < TO **x** AND COMPLETELY REWROTE CHARACTER DEFINITION

PG.47 - IN **RFL** COMMAND, CHANGED **s** DEFINITION TO READ **Sign always '-'**

PG.47 - IN **RFL** COMMAND, ADDED **If signal is less than detectable limit this value will be 60.0**

PG.49 - ADDED **STANDARD MODE** AND **BACKWARD COMPATIBILITY MODE** COMMAND SEQUENCES TO

**MEM** COMMAND

PG.56 - CHANGED **VERSION** TO **FIRMWARE TITLE AND VERSION** AND REWROTE COMMAND SETS

PG.65 - UPDATED **FIGURE 5-25**

PG 65 - REPLACED **TEST DESTINATION** AND **SEND A TEST TRAP** WITH **PARITY, ADDRESS, BUS AND**

**BAUD RATE**

PG.66 - UPDATED **FIGURE 5-26**

PG.66 - ADDED **SET CLOCK TO COMPUTER DATE/TIME**

PG.67 - UPDATED **FIGURE 5-27**

PG.67 - REMOVED **UNIT NAME** AND **PASSWORD DISABLED**, AND ADDED **ENABLE TRAPS, TRAP REPEAT**

**RATE, ENABLE FIRMWARE UPGRADE AND ENABLE TEST ALARM**

PG.69 - ADDED SENTENCE ABOUT DOWNLOADING MIB FILE AND REMOVED FINAL SENTENCE

REGARDING INACCESSIBILITY RENDERING OF SNMP IN **ACCESS VIA SNMP**

PG.71 - NEW **FIGURE 5-32**

PG.74 - BLOCK 182945 REV.A TO REV.B

11/4/09: REV.D TO REV.D (FINAL)

PG.1 - NEW **FIGURE 1-2**

PG.5 - ADDED **1.5:1** TO **VSWR**

PG.5 - REMOVED **SIGNAL ACQUISITION**

PG.5 - ADDED **ACQUISITION TIME TABLE**

PG.5 - CHANGED **AC POWER** TO **DC FAULT** IN **STATUS ALARMS**

PG.5 - CHANGED **POWER CONSUMPTION** FROM **50 W** TO **35 W**

PG.11 - ADDED NEW **STEP 5** (After a firmware upgrade...) TO BOTH **FREQUENCY CONFIGURATION**

**COMPATIBILITY PROCEDURES**

PGS.34&40 - CHANGED **Ssn** TO **Ssnn** AND **Gggg** TO **Gsgg** IN **STANDARD & BACKWARD COMPATIBLE**

**MODE**

PG.45 - CHANGED **Four** TO **Five** IN **BACKWARD COMPATIBLE MODE** RESPONSE DESCRIPTION

PG.46 - ADDED **If the password has been disabled...** TO **PWD** COMMAND

PG.49 - CHANGED **Ssn** TO **Ssnn** AND **Gggg** TO **Gsgg** IN **STANDARD & BACKWARD COMPATIBLE MODE**

PG.63 - ADDED DESCRIPTION OF **LIVE SPECTRUM PLOT**

PG.64 - ADDED **FIGURE NEW FIGURE 5-24** (LIVE SPECTRUM PLOT); REPAGED AND RENUMBERED REST

OF MANUAL.

PG.72 - ADDED NEW FINAL BULLET (After a firmware upgrade...)

## TABLE OF CONTENTS

<b>SECTION 1: INTRODUCTION</b>	<b>1</b>
GENERAL DESCRIPTION	1
PHYSICAL	1
EQUIPMENT CHARACTERISTICS	2
PHYSICAL	2
Connector Wiring Information	3
FUNCTIONAL	5
<b>SECTION 2: PRINCIPLES OF OPERATION</b>	<b>6</b>
DEFINITION OF TERMS	6
<b>SECTION 3: INSTALLATION</b>	<b>9</b>
UNPACKING, STORAGE, RESHIPMENT	9
MOUNTING	9
TURN-ON PROCEDURE	9
<b>SECTION 4: CONFIGURATION AND SETUP OF THE BEACON RECEIVER</b>	<b>11</b>
FREQUENCY COMPATIBILITY CONFIGURATION PROCEDURE	11
Backward Compatibility Configuration (Frequency In MHz)	11
Standard Command Configuration (Frequency In Hz)	11
CONFIGURING THE BEACON RECEIVER	11
<b>SECTION 5: OPERATION</b>	<b>12</b>
CONTROLS	12
EXTERNAL CONTROLS	12
AC Power	12
Fuses	12
INTERNAL CONTROLS	12
Power Supply Output Voltage Adjustment	12
RS485/RS422 Bus Termination	12
FRONT PANEL OPERATIONS	12
KEYPAD OPERATION	13
Menu Key	13
Cursor Key	13
Data Entry Keys	13
MAIN MENU	14
ALARM MENU	15
RF GAIN MENU	17
IF GAIN MENU	17
ACQUISITION MENU	18
VIDEO BANDWIDTH MENU	19
OUTPUT MENU	20
MEMORY FUNCTIONS MENU	21
REMOTE INTERFACE MENU	23
ETHERNET CONFIGURATION MENU	24
RECEIVER TITLE MENU	25
UTILITY MENU	25
RECEIVER REVISION DISPLAY	26
REMOTE OPERATIONS	27
SERIAL REMOTE PROTOCOL (RS485/RS422/RS232)	27
SERIAL MESSAGE FORMAT	27
COMMAND CODE SUMMARY	29
SYSTEM FAULT STATUS = ALR	30
INTERNAL CALENDAR/CLOCK = CLK	33
DELTA SIGNAL LEVEL = DEL	33

## TABLE OF CONTENTS

### SECTION 5: OPERATION (CONTINUED)

SET ALL ETHERNET PARAMETERS = EAD	34
INPUT FREQUENCY = FRQ	35
OUTPUT HOLD TIME = HOL	36
RECEIVER EVENT LOG ENTRIES = LOG	37
UNIT MEMORY REGISTER STORE/RECALL = MEM	39
MEASUREMENT MODE = MMD	42
MINIMUM VOLTAGE = MNV	43
MODEL = MOD	43
IF GAIN = MVL	44
MAXIMUM VOLTAGE = MXV	44
FREQUENCY OFFSET = OFF	45
OUTPUT VOLTAGE = OUT	45
ETHERNET PASSWORD = PWD	46
SIGNAL STRENGTH = PWR	46
REFERENCE LEVEL = REF	46
REMOTE/LOCAL CONTROL MODE = REM	47
RF GAIN = RFG	47
RF SIGNAL LEVEL = RFL	47
REFERENCE VOLTAGE = RFV	48
RECEIVER TITLE = RTL	48
UNIT MEMORY REGISTER STORE/RECALL AND SET = SET	49
OUTPUT SLOPE = SLP	53
SIGNAL TO NOISE RATIO = SNR	53
TUNER BANDWIDTH = TBW	54
TEMPERATURE = TMP	54
TRACKING RANGE = TRK	55
VIDEO BANDWIDTH = VBW	55
FIRMWARE TITLE AND VERSION = VER	56
SYSTEM VOLTAGES = VLT	56
EXTERNAL REFERENCE = XRF	57
EXAMPLES	57
ETHERNET INTERFACE	58
CONNECTION	58
SET UP	58
CONFIGURING INTERNET PROTOCOL (IP) OPERATING PARAMETERS	59
CONFIGURING VIA SERIAL INTERFACE	60
CONFIGURING VIA IPSETUP APPLICATION	60
VERIFYING PROPER CONNECTION AND CONFIGURATION	61
ACCESSING THE SYSTEM THROUGH THE ETHERNET CONNECTION	61
ACCESS VIA THE WEB INTERFACE	61
ACCESS VIA TELNET	71
FIRMWARE UPGRADE	72
SET UP GUIDE	73

### SECTION 6: BEACON RECEIVER COMPONENT PRINCIPLES OF OPERATION 74

INTRODUCTION	74
RF MODULE FUNCTIONAL DESCRIPTION	74
DSP BOARD FUNCTIONAL DESCRIPTION	74
MAJOR SUBASSEMBLIES FUNCTIONAL DESCRIPTION	77
RF MODULE	77
POWER SUPPLY	77

### SECTION 7: MAINTENANCE 78

PREVENTIVE MAINTENANCE	78
POWER SUPPLIES	78

## FIGURES & TABLES

Figure 1-1. Front View, L-Band Beacon Receiver	1
Figure 1-2. Rear View, L-Band Beacon Receiver	1
Figure 1-3. Interior View, L-Band Beacon Receiver	2
Table 2-1. Incremental Steps In Tuner Bandwidth	6
Table 2-2. Incremental Steps In Acquisition Range	6
Table 2-3. Incremental Steps In Tracking Range	6
Table 2-4. Video Bandwidth Selections	7
Table 2-5. Incremental Steps In Output Slope	8
Table 2-6. Holdtime Selections	8
Table 3-1. External Connections	10
Figure 5-1. Backwards Compatible Main Menu Display	14
Figure 5-2. Standard Main Menu Display	14
Figure 5-3. Alarm Menu Display	15
Figure 5-4. Active Alarms Display	15
Figure 5-5. Event Log Display	16
Figure 5-6. RF Gain Menu Display	17
Figure 5-7. IF Gain Menu Display	17
Figure 5-8. Acquisition Menu Display #1	18
Figure 5-9. Acquisition Menu Display #2	19
Figure 5-10. Carrier to Noise Menu Display	19
Figure 5-11. Output Menu Display	20
Figure 5-12. Memory Functions Menu Display #1	21
Figure 5-13. Memory Functions Menu Display #2	21
Figure 5-14. RS485 Display Lines 1 and 2	23
Figure 5-15. Ethernet Configuration Menu Display #1	24
Figure 5-16. Ethernet Configuration Menu Display #2	24
Figure 5-17. Final Ethernet Configuration Menu Display	25
Figure 5-18. Receiver Title Menu Display	25
Figure 5-19. Utility Menu Display	25
Figure 5-20. Receiver Revision Display	26
Figure 5-21. IPSETUP Application	61
Figure 5-22. Login Screen	62
Figure 5-23. Home Screen	63
Figure 5-24. Live Spectrum Plot Screen	64
Figure 5-25. Memory Screen	65
Figure 5-26. Communications Screen	66
Figure 5-27. Time and Date Screen	67
Figure 5-28. Miscellaneous Settings Page	68
Figure 5-29. Event Log Page	69
Figure 5-30. Logout Page	70
Figure 5-31. Opening Telnet Port	71
Figure 5-32. Telnet Communications	71
Figure 5-33. AutoUpdate Application Screens	72
Figure 6-1. Block Diagram, Beacon Receiver	75
Table 5-1. Ethernet Cable Wiring	58

# SECTION 1: INTRODUCTION

## GENERAL DESCRIPTION

The MITEQ BR series Beacon Receiver is a versatile receiver designed to lock onto a CW or modulated carrier and provide accurate and reliable relative power measurement indicators for either antenna positioning or uplink power control applications.

The BR-L operates in the L-Band and accepts a 940-2150 MHz signal. The outputs of the beacon receiver are analog and digital indicators of power measured at the input of the beacon receiver. The beacon receiver fits neatly into a single EIA standard rack height (1.75 inches).

A rich feature set of controls and indicators are easily accessible via an intuitive operating environment. The receiver can be setup completely from the front panel or over a remote bus via a host computer. There are thirty-two memory locations where various settings can be stored and recalled easily. Also, a log is continuously updated with time-stamped records of alarm activity.

## FEATURES

- RS485/RS422 selectable remote interface
- Contact closure status outputs
- 10/100 Base-T Ethernet interface providing:
  - HTTP-based web server
  - SNMP 1.0 configuration
  - Alarm reporting via SNMP trap
  - Telnet access
  - Password protection and selectable RS485/422

## PHYSICAL

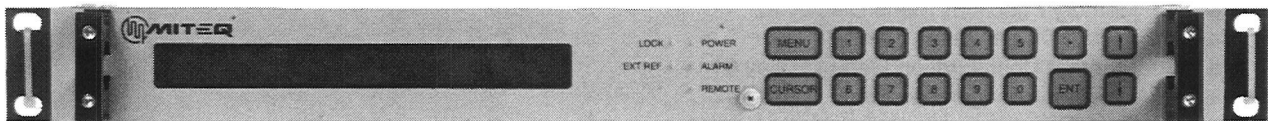

Figure 1-1. Front View, L-Band Beacon Receiver



Figure 1-2. Rear View, L-Band Beacon Receiver



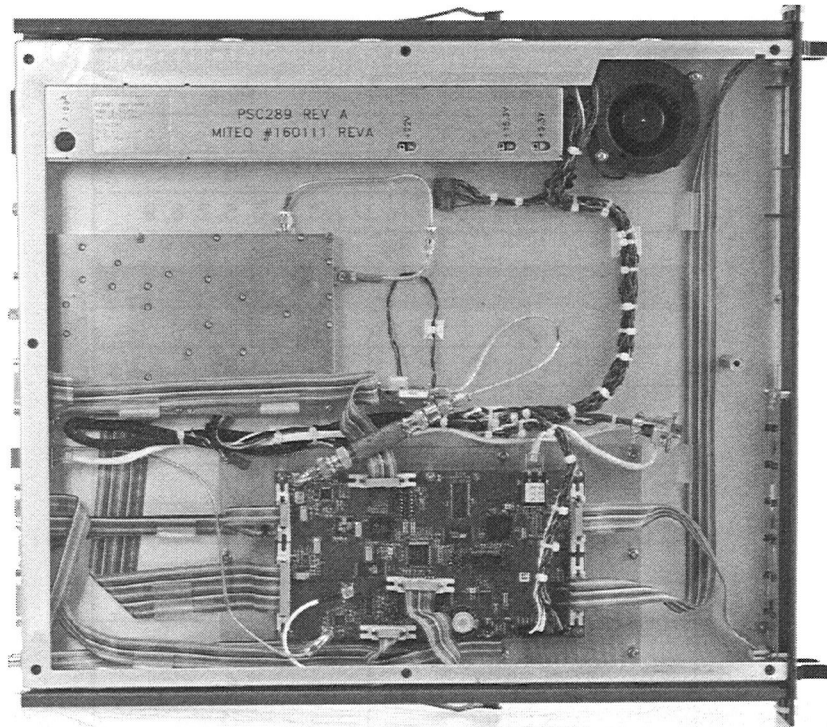

Figure 1-3. Interior View, L-Band Beacon Receiver

## EQUIPMENT CHARACTERISTICS

### PHYSICAL

Weight.....	15 pounds nominal
Chassis dimensions.....	19" x 1.75" panel height x 22" maximum
Connectors	
L-Band input .....	SMA female
L-Band input monitor .....	SMA female
External reference .....	BNC female
Beacon level analog output .....	DE-9S
Beacon level digital output .....	DA-15S
Beacon receiver status output .....	DA-15P
Remote interface.....	DE-9S for RS485, RS422 and RS232,
Ethernet interface .....	RJ-45
Primary power input.....	IEC-320
Ground Lug.....	10-32 screw w/washers

## Connector Wiring Information

BEACON RECEIVER ANALOG OUTPUT (J7)	
Signal	Pins
Voltage Output 'A'	4
Voltage Output 'B'	6
Ground	1, 2, 3, 5, 7, 8, 9

BEACON RECEIVER DIGITAL OUTPUT (J10)	
Signal	Pins
Data Bit 00	8
Data Bit 01	15
Data Bit 02	7
Data Bit 03	14
Data Bit 04	6
Data Bit 05	13
Data Bit 06	5
Data Bit 07	12
Data Bit 08	4
Data Bit 09	11
Data Bit 10	3
Data Bit 11	10
Ground	1, 2
Clock	9

A digital video word is output at J4 of the beacon receiver. The digital word is a 12-bit binary representation of the output voltage. A binary zero represents -10 volts and a full count of all "1"s represents +10 volts. Thus the bit weight is approximately five millivolts. Pin designations are indicated in the table below.

BEACON RECEIVER STATUS OUTPUT (J9)			
Alarm	Pins	Normal	Fault
Summary	1, 9	Closed	Open
Summary	2, 9	Open	Closed
DC Power	4, 12	Closed	Open
DC Power	5, 12	Open	Closed
Receiver Lock	10, 3	Closed	Open
Receiver Lock	11, 3	Open	Closed
Input Level Low	13, 6	Closed	Open
Input Level Low	14, 6	Open	Closed
Local Oscillator	7, 15	Closed	Open
Local Oscillator	8, 15	Open	Closed

ETHERNET INTERFACE CONNECTOR (J10)		
RJ-45 Pin#	Wire Color	10BaseT Signal Name
1	White/Orange	Transmit+
2	Orange	Transmit-
3	White/Green	Receive+
4	Blue	Un-used
5	White/Blue	Un-used
6	Green	Receive-
7	White/Brown	Un-used

RS485 & RS422 (J6)	
Pin	Designation
1	Ground
2	Un-used
3	Data Out -
4	Un-used
5	Data In -
6	Un-used
7	Data Out +
8	Un-used
9	Data In +

For RS485 two-wire party line operation, DATA IN + must be externally wired to DATA OUT +, and DATA IN - externally wired to DATA OUT -.

RS232 (J6)	
Pin	Designation
1	Un-used
2	Data Out
3	Data In
4	Un-used
5	Ground
6	Un-used
7	Un-used
8	Un-used
9	Un-used

For RS232 operation, install jumper on J16 of the FFT/DSP control board. The rear panel connector plugs into an RS232 interface adapter board which connects to J1 of FFT/DSP control board.

The Beacon Receiver RS232 interface is DCE type (Data Communications Equipment) and does not require a null modem when connecting up to the M&C computer.

## FUNCTIONAL

BEACON RECEIVER PERFORMANCE SPECIFICATIONS																																								
RF/IF Performance	940-2150 MHz																																							
Input frequency	-100 to -30 dBm																																							
Dynamic range	340 kHz, 150 kHz, 7.5 kHz																																							
IF preselector bandwidth	L-Band input; 50 ohms																																							
Impedance	1.5:1 (15 dB Return Loss)																																							
VSWR	1.5 x 10 <sup>-6</sup> internal reference, external reference optional																																							
Frequency stability																																								
External Reference	10 MHz, +4±3 dBm Unit will automatically switch to internal reference if External Reference level falls below +1 dBm nominal.																																							
Signal Detection	Total power detection in predetermined bandwidth or unmodulated CW beacon power																																							
Acquisition search range	±10 to ±700 kHz fixed increments																																							
Acquisition time	0.4 to 8 seconds maximum (bandwidth dependent) 0.4 to 2 seconds typical																																							
	<table border="1"> <thead> <tr> <th>Typical Acquisition Time (msec)</th> <th>Tuner Bandwidth (kHz)</th> <th>Acquisition Range (kHz)</th> </tr> </thead> <tbody> <tr> <td>390</td> <td>7.5</td> <td>±10</td> </tr> <tr> <td>450</td> <td>150</td> <td>±200</td> </tr> <tr> <td>470</td> <td>7.5</td> <td>±20</td> </tr> <tr> <td>720</td> <td>150</td> <td>±500</td> </tr> <tr> <td>780</td> <td>7.5</td> <td>±50</td> </tr> <tr> <td>780</td> <td>340</td> <td>±500</td> </tr> <tr> <td>900</td> <td>340</td> <td>±700</td> </tr> <tr> <td>920</td> <td>150</td> <td>±700</td> </tr> <tr> <td>1300</td> <td>7.5</td> <td>±100</td> </tr> <tr> <td>2300</td> <td>7.5</td> <td>±200</td> </tr> <tr> <td>5500</td> <td>7.5</td> <td>±500</td> </tr> <tr> <td>7600</td> <td>7.5</td> <td>±700</td> </tr> </tbody> </table>	Typical Acquisition Time (msec)	Tuner Bandwidth (kHz)	Acquisition Range (kHz)	390	7.5	±10	450	150	±200	470	7.5	±20	720	150	±500	780	7.5	±50	780	340	±500	900	340	±700	920	150	±700	1300	7.5	±100	2300	7.5	±200	5500	7.5	±500	7600	7.5	±700
Typical Acquisition Time (msec)	Tuner Bandwidth (kHz)	Acquisition Range (kHz)																																						
390	7.5	±10																																						
450	150	±200																																						
470	7.5	±20																																						
720	150	±500																																						
780	7.5	±50																																						
780	340	±500																																						
900	340	±700																																						
920	150	±700																																						
1300	7.5	±100																																						
2300	7.5	±200																																						
5500	7.5	±500																																						
7600	7.5	±700																																						
Tracking range	same as acquisition search range																																							
Acquisition threshold	≥ 35 dB-Hz, C/N on the tuner bandwidth (bandwidth dependent)																																							
Carrier tracking threshold	≥ 30 dB-Hz, C/N in the tuner bandwidth (bandwidth dependent)																																							
Anti-sideband lock	Prevents receiver from locking on a telemetry sideband when the C/I is ≥ 3 dB																																							
Signal Outputs																																								
Digital output	12-bit binary word output																																							
Analog outputs	Two identical outputs with a 20 volt range programmable from -10 to +10V																																							
Coupling	DC																																							
Frequency response	0.1 to 10 Hz programmable in fixed increments																																							
Source impedance	25 ohms nominal																																							
Output current	20 milliamps maximum with short circuit protection																																							
Output sensitivity	±0.5, 1.0, 2.0, 4.0, 6.0 and 8.0 dB/V																																							
Status Alarms	Summary, local oscillator, input level low, receiver lock and DC fault																																							
Primary Power	90-250VAC																																							
Power Consumption	35 W nominal																																							
Environmental (Operating)																																								
Ambient temperature	0 to 50°C																																							
Relative humidity	Up to 95% at 30°C																																							
Atmospheric pressure	Up to 10,000 feet																																							
Environmental (Non-operating)																																								
Ambient temperature	-50 to +70°C																																							
Relative humidity	Up to 95% at 40°C																																							
Atmospheric pressure	Up to 40,000 feet																																							
Shock and Vibration	Normal handling by commercial carriers																																							

## SECTION 2: PRINCIPLES OF OPERATION

### DEFINITION OF TERMS

The terms and phrases below are used throughout the following discussion. Their use in this context is defined here for clarity.

**Input Frequency** – This is the user-specified center frequency to which the beacon receiver is initially tuned.

**Delta Frequency** – This is the difference between the measured Carrier Frequency and the actual center frequency to which the receiver is tuned.

**Tuner Bandwidth** – This is the bandwidth surrounding the center frequency to which the receiver is actually tuned. **Tuner Bandwidth** is user-selectable from the predetermined steps listed below.

TABLE 2-1. INCREMENTAL STEPS IN TUNER BANDWIDTH
7.5 kHz
150 kHz
340 kHz

**Acquisition Range** – The search for a carrier is limited to a specific frequency range defined as the **Acquisition Range**. The **Acquisition Range** is with respect to the user-specified Input Frequency and the Frequency Offset. The **Acquisition Range** can be adjusted in fixed increments from +/- 10 kHz to +/- 700 kHz. Must be greater than **Tuner Bandwidth**.

TABLE 2-2. INCREMENTAL STEPS IN ACQUISITION RANGE
±0 kHz
±10 kHz
±20 kHz
±50 kHz
±100 kHz
±200 kHz
±500 kHz
±700 kHz

**Tracking Range** – Once a carrier has been acquired the beacon receiver will maintain lock so long as the carrier does not drift outside of the **Tracking Range**. The tracking range is user programmable from +/-10 kHz to ±700 kHz. The **Tracking Range** is always with respect to the user-specified Input Frequency. Must be greater than **Tuner Bandwidth**.

TABLE 2-3. INCREMENTAL STEPS IN TRACKING RANGE
±10 kHz
±20 kHz
±50 kHz
±100 kHz
±200 kHz
±500 kHz
±700 kHz

**Gain Controls** – The receiver architecture provides two independent user-adjustable gain controls. The first gain control is a wideband adjustment situated at the front end of the receiver. This is referred to as the RF Gain. The second gain control is a narrowband adjustment centered around an intermediate frequency. This is referred to as the IF Gain adjustment.

**RF Gain Control** – The RF gain must be adjusted to bring the input signal within the receiver’s front end dynamic range. A digital display shows the RF signal level and a bar graph display shows the RF Gain position within a 20 dB window. If the RF Gain is outside the 20 dB window an arrow will appear at the end of the bar graph display to indicate the gain level position is outside the window. A cursor is adjusted to be in the center of the 20 dB gain window. “OVER-RANGE” is indicated and an alarm is logged if the gain is set too high. “RF LEVEL LOW” is indicated if RF power is < -60 dBm

**IF Gain Control** – The IF gain must be adjusted to optimize the internal signal level. This is best done in AGC mode where the IF Gain adjustment is made automatically by the receiver. In the MGC mode the IF gain must be adjusted manually to bring the input signal within the receiver’s back end dynamic range after it has been multiplied by the RF Gain. In the MGC mode both the IF and RF Gain settings can cause the IF Gain window to indicate “OVER-RANGE”. An alarm is logged if the gain is set too high.

**Video Bandwidth** – The rate at which the measured Signal Strength is averaged. Below are the valid selections for Video Bandwidth.

TABLE 2-4. VIDEO BANDWIDTH SELECTIONS
0.10 Hz
0.20 Hz
0.50 Hz
1.00 Hz
2.00 Hz
5.00 Hz
10.00 Hz

**Signal Strength** – The power measured at the beacon receiver input.

**Reference Level** – A user-defined reference to a specific Signal Strength. Typically in uplink power control applications the **Reference Level** represents the Signal Strength that will be measured during periods of minimal atmospheric attenuation. For antenna positioning operations **Reference Level** would indicate the Signal Strength during optimum antenna positioning. The operator can set the **Reference Level** between –10 dBm and –110 dBm in steps of 0.1 dB. The **Reference Level** can be set to the measured Signal Strength by moving the cursor to that field and pressing enter on the Main Menu Display.

**Delta Level** – The difference between the Signal Strength and the Reference Level.

**Output Voltage** – Appears at both the rear panel DC voltage output connectors. Output voltage is a function of Signal Strength, Reference Level, Reference Output Voltage, and Output Slope. The Maximum Voltage and Minimum Voltage settings limit output voltage. **Output Vltg = Ref Output Vltg + (Signal Strength – Ref Level)/Output Slope**

**Reference Output Voltage** – A user-selected voltage that represents the Reference Level. Output voltage is a function of Signal Strength, Reference Level, Reference Output Voltage, and Output Slope. The **Reference Output Voltage** is user-programmable from –10 volts DC to +10 volts DC in 10 millivolt increments, and cannot be lower than the Minimum Voltage or higher than the Maximum Voltage.

**Maximum Voltage** – A user-programmable upper limit to the output voltage. The **Maximum Voltage** is settable from –10 to +10 volts. The **Maximum Voltage** must be greater than or equal to the Reference Voltage.

**Minimum Voltage** – A user-programmable lower limit to the output voltage. The **Minimum Voltage** is settable from –10 to +10 volts. The **Minimum Voltage** must be less than or equal to the Reference Voltage.

**Output Slope** – A user-programmed slope used to determine the output voltage for a given Signal Strength. A positive **Output Slope** indicates that the Output Voltage will increase with Signal Strength. A negative **Output Slope** will cause the Output Voltage to decrease while the Signal Strength is increasing. The **Output Slope** can be set to the values shown below.

TABLE 2-5. INCREMENTAL STEPS IN OUTPUT SLOPE
-10.0 dB/V
-8.0 dB/V
-6.0 dB/V
-4.0 dB/V
-2.0 dB/V
-1.0 dB/V
-0.5 dB/V
+0.5 dB/V
+1.0 dB/V
+2.0 dB/V
+4.0 dB/V
+6.0 dB/V
+8.0 dB/V
+10.0 dB/V

**Holdtime** – The Holdtime setting determines how long after the Beacon Receiver loses lock it will maintain the output voltage at the last known good value. If lock has not been restored before the selected Holdtime elapses the output voltage will go to the selected Minimum or Maximum levels depending on the sign of the selected Slope.

TABLE 2-6. HOLDTIME SELECTIONS
0 seconds
1 seconds
2 seconds
5 seconds
10 seconds
15 seconds
30 seconds
60 seconds
120 seconds
300 seconds
600 seconds

**Power Measurement Mode** – The beacon receiver can report measured power as the peak power at a single frequency or the total power measured in the IF bandwidth to include any contribution from modulation sidebands.

## SECTION 3: INSTALLATION

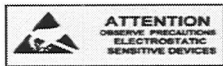

**PROPER GROUNDING PRECAUTIONS  
ARE REQUIRED AT ALL TIMES TO  
PREVENT DAMAGE FROM ESD WHILE  
HANDLING THIS UNIT**

### UNPACKING, STORAGE, RESHIPMENT

Carefully open the shipping container and remove the equipment. Inspect the equipment thoroughly and report any damage.

If the equipment is to be stored, it should be wrapped in plastic and kept in a clean, dry place.

If the equipment is to be reshipped for any reason, wrap in heavy plastic and ship in a heavy (275 lb. test) double wall carton. At least three inches of a solid packing material should be used on all sides of the unit. The carton should be marked to indicate that it contains fragile electronic equipment.

### MOUNTING



**This equipment is NOT for use in a domestic environment. It is intended for rack mounting. This equipment MUST be securely mounted; Operator injury may occur if this is not done.**

Slides are provided for mounting in a standard 19" equipment rack.

### TURN-ON PROCEDURE

After mounting, connect the ground lug and the AC Power Cord per Table 3-1.



**DO NOT make any other connections until the output voltage limits have been set properly!**

Apply power to the equipment by switching the rear panel power ON/OFF switch into the ON position.

Refer to Section 5 to set the output voltage limits in accordance with the recommendations of the manufacturer of the ancillary equipment.

Remove power from the equipment by switching the rear panel power ON/OFF switch into the OFF position.

Make all external connections per Table 3-1.

Apply power to the equipment by switching the rear panel power ON/OFF switch back to the ON position.

System is now operational.



**TABLE 3-1. EXTERNAL CONNECTIONS**

DESIGNATION	DESCRIPTION
Ground Lug	Connect the Ground Lug on the rear panel of the equipment to the Protective Earth connection of the building.
AC Power Cord	Attach power cords to the rear panel AC power inlet marked "PS. Connect the other end to the power source. Refer to national wiring standards for the correct connection to the power source.
Status Output Connector (J9)	The Status output connector is a contact closure status output indicating the status of the DC Power, Receiver Lock Status, Signal Strength, Local Oscillator Status, and provides a summary alarm output for the Beacon Receiver. See Section 1 for wiring information.
Remote Interface Connector (J6)	The Remote Interface connector is an optional connection. This allows the operator to monitor and control the equipment from a remote location. See Section 1 for wiring information.
Ethernet Interface Connector (J16)	The Ethernet Interface connector is an optional connection. This allows the operator to monitor and control the equipment via an Ethernet network connection. See Section 1 for wiring information.
L-Band Input Signal Connector (J1)	Connect the L-Band input signal to the rear panel Input connector (J1).
Beacon Level Analog Output Voltage Connector (J7)	Connect the output voltage signals from the rear panel Output connector (J7) to the subsequent system components. See Section 1 for wiring information.
Beacon Level Digital Output Connector (J10)	Connect the digital output signals from the rear panel Output connector to the intended system component.
External Frequency Reference Input Connector (J12)	Connect the system component frequency reference to the rear panel External Frequency Reference Input Connector (J12).

## SECTION 4: CONFIGURATION AND SETUP OF THE BEACON RECEIVER

### FREQUENCY COMPATIBILITY CONFIGURATION PROCEDURE

#### Backward Compatibility Configuration (Frequency In MHz)

1. Turn off the Beacon Receiver.
2. Turn on the Beacon Receiver while holding the numeral '1' on the front panel display.
3. Hold the key down until the message 'Setting backward compatibility commands' is displayed.
4. The unit will now come up with the frequency displayed in 'MHz' and the offset displayed in 'kHz'. The frequency display may have an erratic frequency at first.
5. After a firmware upgrade it is recommended to return the unit to its factory default settings. That is done by power cycling the unit with the "down" arrow key held down. When the unit displays "erasing memory" the key can be released. All user settings will need to be restored at that point.
6. Re-enter the frequency and the unit should come to a correct entry in 'MHz'.

#### Standard Command Configuration (Frequency In Hz)

1. Turn off the Beacon Receiver.
2. Turn on the Beacon Receiver while holding the numeral '2' on the front panel display.
3. Hold the key down until the message 'Setting backward compatibility commands' is displayed.
4. The unit will now come up with the frequency displayed in 'Hz' and the offset also displayed in 'Hz'. The frequency display may have an erratic frequency at first.
5. After a firmware upgrade it is recommended to return the unit to its factory default settings. That is done by power cycling the unit with the "down" arrow key held down. When the unit displays "erasing memory" the key can be released. All user settings will need to be restored at that point.
6. Re-enter the frequency and the unit should come to a correct entry in 'Hz'.

### CONFIGURING THE BEACON RECEIVER

It is recommended that the parameters outlined in the following section be configured to satisfy that intended application.

- Set the beacon receiver date and time
- Tune the beacon receiver to the proper frequency.
- Set the beacon receiver tuner bandwidth and acquisition and tracking ranges.
- Set the voltage outputs of the beacon receiver to match the desired application.
- Set the beacon receiver RF and IF Gains.
- Set the beacon receiver Reference Level.
- Set the remote communications parameters.
- Clear the beacon receiver Event Log.

The configuration of the beacon receiver can be done from the front panel menu operations described below. If the beacon receiver is to be configured remotely, set the remote parameters first then use the remote commands to setup the beacon receiver.

## **SECTION 5: OPERATION**

### **CONTROLS**

#### **EXTERNAL CONTROLS**

For a description of the front panel keys and select switches see Page 13.

#### **AC Power**

Use the Power Supply power on/off switch to control AC power to the unit.

#### **Fuses**

The fuse is accessible from the top cover of the unit, towards the rear corner closest to the AC power input. The fuse value is T1.25A.

#### **INTERNAL CONTROLS**

##### **Power Supply Output Voltage Adjustment**

Power supply output voltages are adjusted from potentiometers located on the power supply. See Figure 1-3 for location of these adjustments. Any adjustment should be made using an insulated tuning tool. There is no adjustment for the  $-15.3\text{V}$  or the  $+12\text{V}$  supplies. Voltage tolerances for the remaining outputs are  $+18.0 \pm 0.3\text{V}$ ,  $+15.3 \pm 0.2\text{V}$  and  $+5.3 \pm 0.3\text{V}$ .

##### **RS485/RS422 Bus Termination**

A jumper selectable, 120 ohm termination resistor is connected across the DATA + and DATA - terminals. The resistor is installed by connecting a jumper across J5 that is located on the digital control board. Use Figure 1-3 to locate the Control Board and the position of the jumper.

#### **FRONT PANEL OPERATIONS**

A liquid crystal display (LCD) and light emitting diode (LED) indicators have been organized such that important information is available at a glance. The keyboard is divided into functional groups to allow an operator to easily change any parameter from the front panel. See Figure 1-1 for the physical layout of the front panel.

A green "POWER" LED on the front panel is lit when the power supply is on.

A green "LOCK" LED on the front panel is lit when the receiver has detected a carrier and is tracking that carrier.

A red "ALARM" LED indicates an active alarm. The alarm LED lights amber when no alarms are active but alarms have been recorded in the event log. This LED is off when no alarms are active and no alarms have been recorded in the event log.

A green "REMOTE" LED is lit when the unit is under remote control, and is off while the unit is under local control.

A green "EXT REFERENCE" LED is lit when the unit detects an external 10 MHz reference. When the LED is extinguished the internal 10 MHz reference is used.

## KEYPAD OPERATION

The keypad includes two keys that are for menu navigation, a "MENU" key and a "CURSOR" key. A full set of numeric Data Entry keys, along with up and down arrows, simplify operator entries. A beeper will sound to acknowledge each key press. An error tone will sound, and in some cases a warning message will be displayed for illegal entries.

While in Remote mode, local data entry is prohibited. However, all system parameters can be examined.

After thirty seconds of idle time the display will default to the Main Menu.

### Menu Key

The "MENU" key allows the operator to switch the context of the LCD between various menus with ease. The "MENU" key also provides an escape function. Momentarily pressing the "MENU" key will terminate any data entry in progress. This key provides instant access to all pertinent data in both Local and Remote modes. Sequential menu key actions will show the menus in the following order:

- Main Menu
- Alarm Menu
- Carrier to Noise Menu
- RF Gain Menu
- IF Gain Menu
- Acquisition Menu
- Output Voltage Menu
- Memory Functions Menu
- Remote Operation Menu
- Ethernet Configuration Menu
- Receiver Title Menu
- Utility Menu (Date, Time and Contrast Control)
- Receiver Revision Display

### Cursor Key

The "CURSOR" key cycles through each of the data fields in a given menu. This accommodates the simple activation of a field within a menu for data entry. In some cases it is possible to select a specific digit within one of these fields. To do so simply hold down the "CURSOR" key and the cursor will cycle through each digit of the field. While in Remote mode, local data entry is prohibited. However, all system parameters can be examined.

### Data Entry Keys

The Data Entry keys allow the operator to enter specific data into an active field. Data can be entered by using the numeric keypad or the up and down arrows to scroll until the desired setting is displayed and then pressing the "ENT" key. Invalid entries will be ignored and cause an error tone to sound. Any data entry not terminated by pressing the "ENT" key will expire after five seconds, an error tone will sound, and the display will be restored to its prior setting. An entry in progress can be re-initiated by pressing the "MENU" key.

Data can also be scrolled or swept by holding down an arrow key. In cases where fixed increments are not used, a digit can be selected to scroll by holding down the cursor key when an applicable field is highlighted. The cursor will cycle through each of the digits in the field. Release the cursor key when the desired digit is highlighted. Then using the up and down arrows scroll the value of the digit and the receiver operation will be immediately updated without pressing the "ENT" key. This allows the operator to continuously change a setting just by holding down an arrow key. Once the arrow key is released and five seconds have expired the cursor will return to the front of the field.

While in Remote mode, local data entry is prohibited. However, all system parameters can be examined.

## MAIN MENU

The main menu is the default menu at power-up. This menu provides access to the following parameters of the frequency converter:

- Input Frequency
- Delta Frequency
- Delta Level
- Measured Signal Strength
- Output Voltage

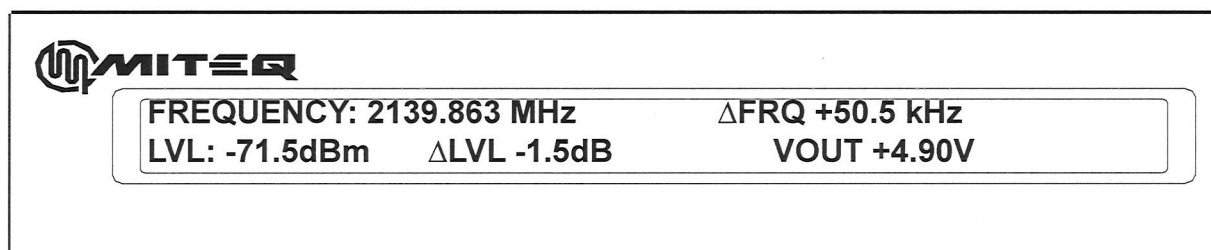

Figure 5-1. Backwards Compatible Main Menu Display

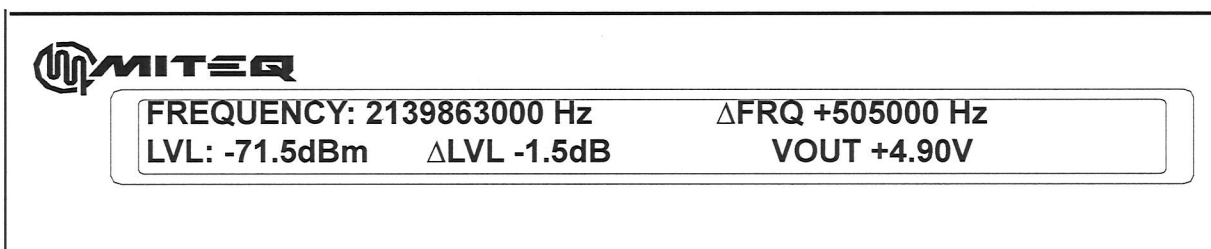

Figure 5-2. Standard Main Menu Display

### FREQUENCY: Input Frequency

To enter the Input Frequency that the unit is tuned to:

- Press the "CURSOR" key to highlight the Input Frequency field on the display.
- Use the numeric data entry keys to enter the desired frequency in MHz.
- Press "ENTER" to tune the unit to the desired frequency.
- If "ENT" is not pressed after five seconds the entry will expire and the display will revert to the frequency that the unit is tuned to.

To step the Input Frequency:

- Press the "CURSOR" key to highlight the Input Frequency field on the display.
- Use the up or down arrow key to increase or decrease the Input Frequency respectively.
- Hold the up or down arrow key to step the digit continuously.
- Pressing "ENT" is not required to accept the entry.

### ΔFRQ: Frequency Offset

The Frequency Offset indicates the difference between the Input Frequency and the actual Frequency onto which the receiver is locked. Frequency Offset is displayed for informational purposes only. This parameter is not user settable. When the receiver is not locked onto a carrier the Frequency Offset will vary while the receiver is attempting to acquire a signal.

### ΔLVL: Level Deviation

The difference between the Signal Strength and the Reference Level is reported here in dB. This parameter is not user settable.

### LVL: Measured Signal Strength

Signal Strength is always reported in this menu. The Signal Strength measurement is displayed in dBm. The Reference Level can be set to the Measured Signal Strength by moving the cursor to that field and pressing enter.

### VOU: Output Voltage

Output Voltage is always reported in this menu. This voltage appears at the rear panel connector J7. The voltage is proportional to the Measured Signal Strength. This parameter is not user selectable. When the receiver is not locked onto a carrier and after the Hold Time has expired the Output Voltage will go to the voltage that the user has programmed to indicate minimum Signal Strength.

$$\text{Output Vltg} = \text{Ref Output Vltg} + (\text{Signal Strength} - \text{Ref Level}) / \text{Output Slope}$$

## ALARM MENU

The Alarm Menu displays the status of the unit's alarms. A "Test Alarm" can be set and cleared from this menu. This menu also allows the operator to review and clear the event log. The Event Log records the time and dates of significant events, including all alarm activity. The "ALARM" LED on the front panel will light red when there is an Active Alarm. If there are no Active Alarms, but alarm activity has been stored in the event log, the front panel "ALARM" LED will light amber.

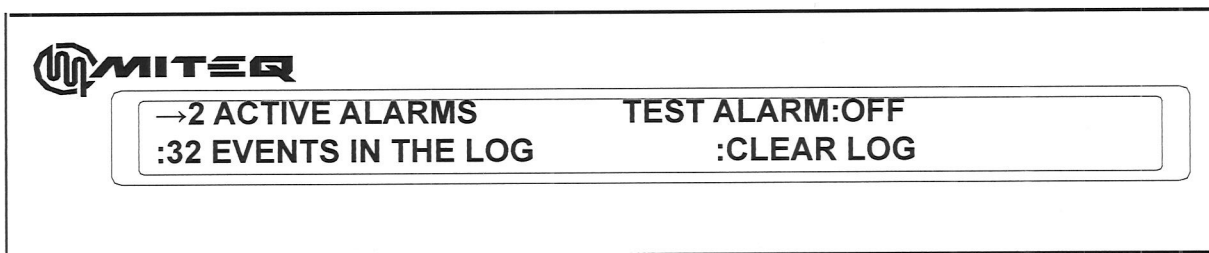

Figure 5-3. Alarm Menu Display

### Active Alarms

The number of active alarms is reported in the Alarm Menu. To view the alarms:

- Press the "CURSOR" key to highlight the Alarms field on the display.
- Use the arrow keys to scroll through all of the active alarms.
- Press the "MENU" key to return to the Alarm Menu.

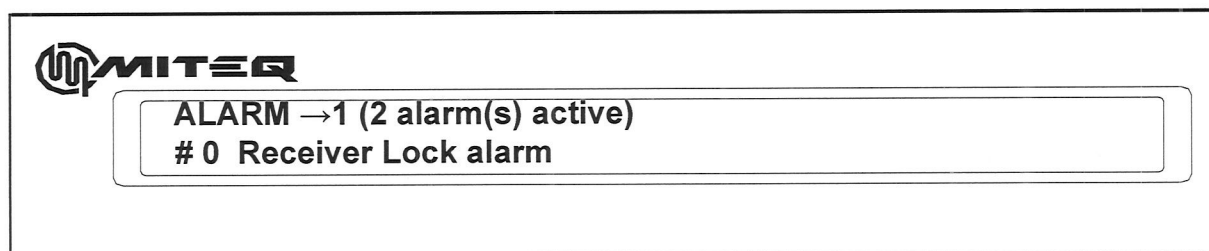

Figure 5-4. Active Alarms Display

The alarms that can be reported are:

- Carrier Lock alarm
- Local Oscillator alarm
- Low Signal Strength alarm
- High Signal Strength alarm
- RF Over-range alarm
- Power Supply
- RF Calibration Error alarm
- IF Over-range alarm
- Test Alarm
-

### Test Alarm

To toggle the state of the Test Alarm:

- Press the "CURSOR" key to highlight the Test Alarm field on the display.
- Use the arrow keys to toggle the display between "ACTIVE" and "INACTIVE"
- Press the "ENT" key to assert the state of the Test Alarm.

### Event Log

To view the Event Log:

- Press the "CURSOR" key to highlight the Event Log field on the display.
- Use the arrow keys to scroll through all of the events stored in the Event Log. Events are displayed in chronological order with the Event 1 as the most recent.
- Press the "MENU" key to return to the Alarm Menu.

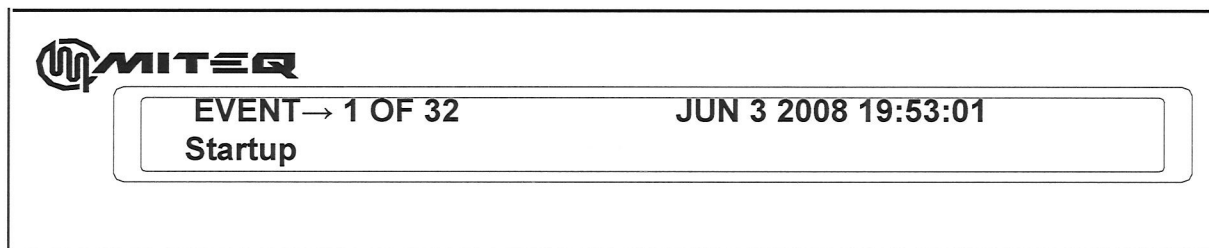

Figure 5-5. Event Log Display

The events that can be reported are:

- Startup
- Carrier Lock alarm
- Carrier Lock alarm recovery
- Local Oscillator alarm
- Local Oscillator alarm recovery
- Low Signal Strength alarm
- Low Signal Strength alarm recovery
- High Signal Strength alarm
- High Signal Strength alarm recovery
- RF Over-range alarm
- RF Over-range alarm recovery
- Power Supply alarm
- Power Supply alarm recovery
- RF Calibration Error
- IF Over-range alarm
- IF Over-range alarm recovery
- Event Log Cleared
- Test Alarm Set
- Test Alarm Cleared
- External Reference change
- Control Mode change

### Clear Event Log

To clear the Event Log of its contents:

- Press the "CURSOR" key to highlight the Clear Log field on the display.
- Press the "ENTER" key. A message will appear "PRESS ENT TO CLEAR THE EVENT LOG."
- Press "ENTER" to purge the contents of the event log or Press the "MENU" key to return to the Alarm menu.

## RF GAIN MENU

The RF Gain Menu provides the operator with access to the parameters that affect the RF gain of the receiver. Measured RF Signal Strength is shown for reference. The parameters shown in this menu are:

- RF Gain Default Set
- RF Gain
- RF Level
- RF Range Meter

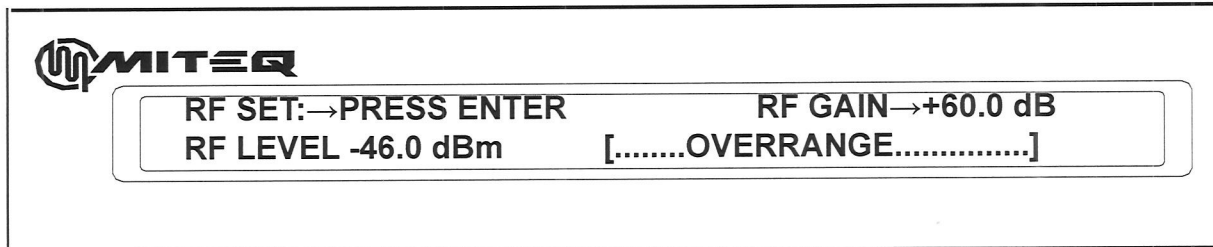

Figure 5-6. RF Gain Menu Display

### RF ADJ: Set RF Gain of Receiver

To set the RF Gain to the default:

- Press "ENT" to accept the default RF Gain.

### RF Gain: Set RF Gain of Receiver

To enter the RF Gain setting manually:

- Use the numeric data entry keys to enter the desired gain in dB.
- Press "ENT" to accept the desired RF Gain.

If "ENT" is not pressed after five seconds, the entry will expire and the display will revert to the RF Gain that the unit is set to.

The RF Range Meter will display the following:

- RF LEVEL LOW - if the RF Gain is too low
- a bar indicating relative signal level within RF Gain range
- OVERRANGE - if the RF Gain is too high

## IF GAIN MENU

The IF Gain Menu provides the operator with access to the parameters that affect the gain of the receiver. Measured Signal Strength is shown for reference. The parameters shown in this menu are:

- IF Gain Control Mode
- IF Gain
- Input Level
- Reference Level

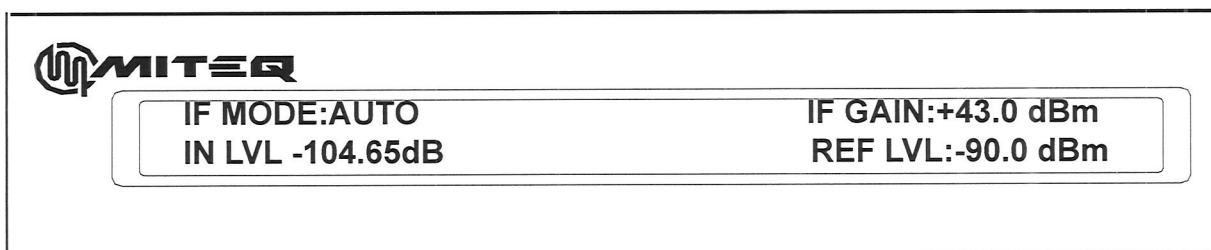

Figure 5-7. IF Gain Menu Display



### IF Gain Control Mode

To toggle between AUTO and MANUAL:

- Press the "CURSOR" key to highlight the IF Mode field on the display.
- Use either arrow key to toggle the display between AUTO and MANUAL.
- Press "ENT" to switch to the displayed IF Gain Control Mode.

If "ENT" is not pressed after five seconds, the entry will expire and the display will revert to the IF Gain Control Mode that the unit is set to.

### IF Gain: IF Gain Level (Manual mode only)

To enter the IF Gain:

- Press the "CURSOR" key to highlight the Manual Input Level field on the display.
- Use the numeric data entry keys to enter the desired Manual Input Level in dBm.
- Press "ENT" to assert the desired Manual Input Level.

If "ENT" is not pressed after five seconds, the entry will expire and the display will revert to the previous Manual Input Level.

### IN LVL: Input Level

Display of input signal level. The Reference Level can be set to the Measured Signal Strength by moving the cursor to that field and pressing "ENT". Numeric input is not accepted.

### REF LVL: Reference Level

To manually enter the Reference Level:

- Press the "CURSOR" key to highlight the Reference Level field on the display.
- Use the numeric data entry keys to enter the desired Reference Level in dBm.
- Press "ENT" to assert the desired Reference Level.

If "ENT" is not pressed after five seconds, the entry will expire and the display will revert to the previous Reference Level.

## ACQUISITION MENU

The Acquisition Menu provides the operator with access to the parameters that influence the acquisition and tracking of a signal. There are three operating parameters, which are spread over two screens. The second screen is reached by pressing the "CURSOR" key to step through each parameter. The "CURSOR" key will continue to cycle through each of the four parameters. The possible parameters are:

- Acquisition Range
- Tracking Range
- Tuner Bandwidth

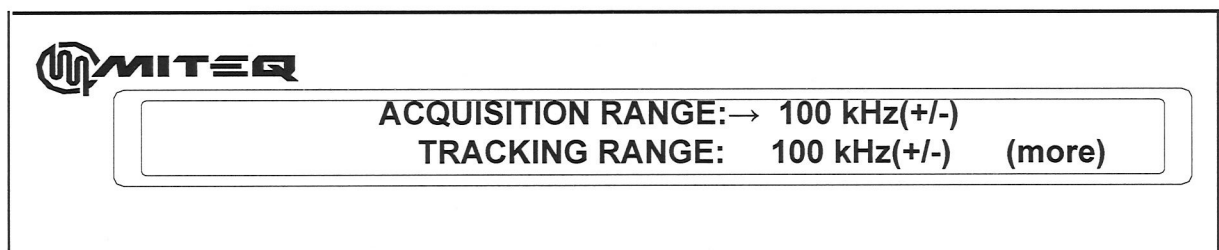

Figure 5-8. Acquisition Menu Display #1

### Acquisition Range

To enter the Acquisition Range:

- Press the "CURSOR" key to highlight the Acquisition Range field on the display.
- Use the arrow keys to scroll through the incremental steps in Acquisition Range.
- Press "ENT" to set the unit to the displayed Acquisition Range.

If "ENT" is not pressed after five seconds, the entry will expire and the display will revert to the previous Acquisition Range.

**Note** *The Acquisition Range must be greater than the Tuner Bandwidth.*

### Tracking Range

To enter the Tracking Range:

- Press the "CURSOR" key to highlight the Tracking Range field on the display.
- Use the numeric data entry keys to enter the desired Tracking Range in kHz.
- Press "ENT" to set the unit to the desired Tracking Range.

If "ENT" is not pressed after five seconds, the entry will expire and the display will revert to the previous Tracking Range.

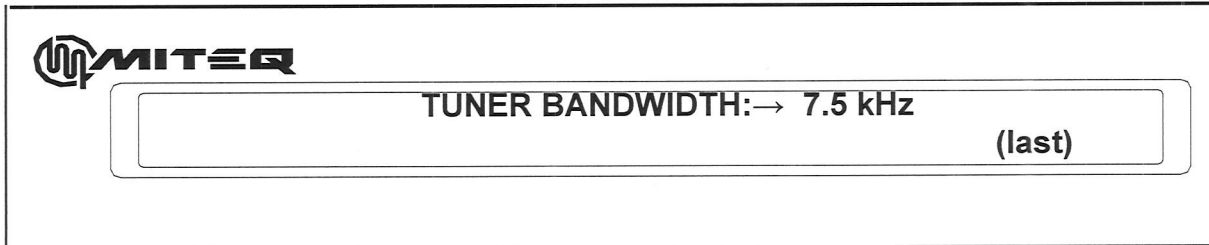

**Figure 5-9. Acquisition Menu Display #2**

**Note** The Tracking Range must be greater than the Tuner Bandwidth.

### Tuner Bandwidth

To enter the Tuner Bandwidth:

- Press the "CURSOR" key to highlight the Tuner Bandwidth field on the display.
- Use the arrow keys to scroll through the incremental steps in Tuner Bandwidth.
- Press "ENT" to set the unit to the displayed Tuner Bandwidth.

If "ENT" is not pressed after five seconds, the entry will expire and the display will revert to the previous Tuner Bandwidth.

**Note** The Tuner Bandwidth should be less than both the Tracking Range and the Acquisition Range.

## VIDEO BANDWIDTH MENU

The Video Bandwidth Menu displays the measured estimate of Carrier to Noise Ratio as well as the internal temperature of the receiver in degrees Celsius. The power measurement mode can be set in this menu.

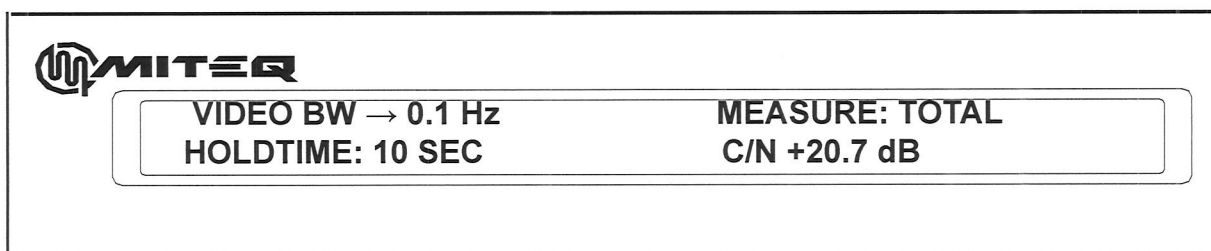

**Figure 5-10. Carrier to Noise Menu Display**

### VIDEO BW: Video Bandwidth

To enter the Video Bandwidth:

- Press the "CURSOR" key to highlight the Video Bandwidth field on the display.
- Use the arrow keys to scroll through the Video Bandwidth selections until the desired Video Bandwidth is displayed.
- Press "ENT" to assert the displayed Video Bandwidth.

If "ENT" is not pressed after five seconds, the entry will expire and the display will revert to the previous Video Bandwidth.

### Power Measurement Mode

To toggle between PEAK and TOTAL:

- Use either arrow key to toggle the display between PEAK and TOTAL.
- Press "ENT" to switch to the displayed mode.

If "ENT" is not pressed after five seconds, the entry will expire and the display will revert to the Power Measurement Mode that the unit is set to.

## Hold Time

To enter the Hold Time:

- Press the "CURSOR" key to highlight the Hold Time field on the display.
- Use the arrow keys to scroll through the incremental steps in Hold Time.
- Press "ENT" to set the unit to the displayed Hold Time.

If "ENT" is not pressed after five seconds, the entry will expire and the display will revert to the previous Hold Time.

Carrier to Noise is an estimate of Carrier to Noise Ratio.

## OUTPUT MENU

The Output Menu provides the operator with access to the parameters that affect the outputs of the receiver. These parameters are:

- Minimum Voltage
- Reference Level Voltage
- Maximum Voltage
- Output Slope
- Output Voltage

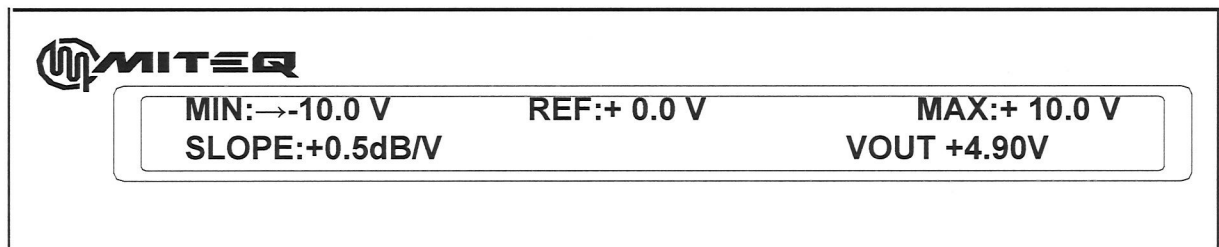

Figure 5-11. Output Menu Display

### MIN: Minimum Voltage

To enter the Minimum Voltage:

- Press the "CURSOR" key to highlight the sign of the Minimum Voltage field on the display.
- Use the arrow keys to choose the sign of the Minimum Voltage.
- Use the numeric data keys to enter the desired Minimum Voltage in volts.
- Press "ENT" to assert the displayed Minimum Voltage.

If "ENT" is not pressed after five seconds, the entry will expire and the display will revert to the previous Minimum Voltage.

**Note** *The Minimum Voltage must be less than or equal to the Reference Level Voltage. If the selected Minimum Voltage is not less than or equal to the Reference Level Voltage an error tone will sound, the entry will expire and the display will revert to the previous Minimum Voltage.*

### REF: Reference Level Voltage

To enter the Reference Level Voltage:

- Press the "CURSOR" key to highlight the sign of the Reference Level Voltage field on the display.
- Use the arrow keys to choose the sign of the Reference Level Voltage.
- Use the numeric data keys to enter the desired Reference Level Voltage in volts.
- Press "ENT" to assert the displayed Reference Level Voltage.

If "ENT" is not pressed after five seconds, the entry will expire and the display will revert to the previous Reference Level Voltage.

**Note** *The Reference Level Voltage must be less than or equal to the Maximum Voltage and greater than or equal to the Minimum Voltage. If the selected Reference is outside the valid range an error tone will sound, the entry will expire and the display will revert to the previous Minimum Voltage.*

### MAX: Maximum Voltage

To enter the Maximum Voltage:

- Press the "CURSOR" key to highlight the sign of the Maximum Voltage field on the display.
- Use the arrow keys to choose the sign of the Maximum Voltage.
- Use the numeric data keys to enter the desired Maximum Voltage in volts.
- Press "ENT" to assert the displayed Maximum Voltage.

If "ENT" is not pressed after five seconds, the entry will expire and the display will revert to the previous Maximum Voltage.

**Note** *The Maximum Voltage must be greater than or equal to the Reference Level Voltage. If the selected Maximum Voltage is not greater than or equal to the Reference Level Voltage an error tone will sound, the entry will expire and the display will revert to the previous Maximum Voltage.*

### SLOPE: Output Slope

To enter the Output Slope:

- Press the "CURSOR" key to highlight the Output Slope field on the display.
- Use the arrow keys to scroll through the Output Slope selections until the desired Output Slope is displayed.
- Press "ENT" to assert the displayed Output Slope.

If "ENT" is not pressed after five seconds, the entry will expire and the display will revert to the previous Output Slope.

### VOU: Output Voltage

Output Voltage is reported in this menu. This voltage appears at the rear panel connector J7. The voltage is proportional to the Measured Signal Strength. This parameter is not user selectable. When the receiver is not locked onto a carrier and after the Hold Time has expired the Output Voltage will go to the voltage that the user has programmed to indicate minimum Signal Strength.

$$\text{Output Vltg} = \text{Ref Output Vltg} + (\text{Signal Strength} - \text{Ref Level})/\text{Output Slope}$$

## MEMORY FUNCTIONS MENU

The Memory Functions Menu allows the operator to save and recall up to sixteen beacon receiver setups and assign a 32-character name to each setup. Each setup includes Input Frequency, IF Gain Control Mode, Hold Time, Minimum Voltage, Reference Voltage, Maximum Voltage, Reference Level, IF Gain, RF Gain, Slope, Acquisition Range, Tracking Range, Tuner Bandwidth and Video Bandwidth. The setup number and title are always displayed on the top line of the LCD. The second line of the LCD is used to review and change memory settings and to set and store memory registers. Default values may be stored for parameters that do not apply to a particular receiver setup.

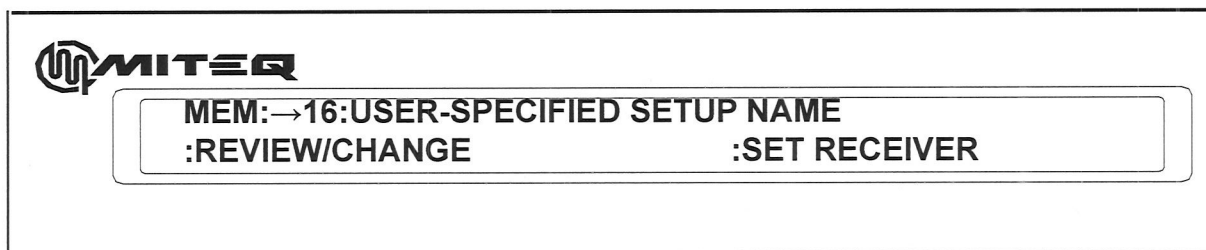

Figure 5-12. Memory Functions Menu Display #1

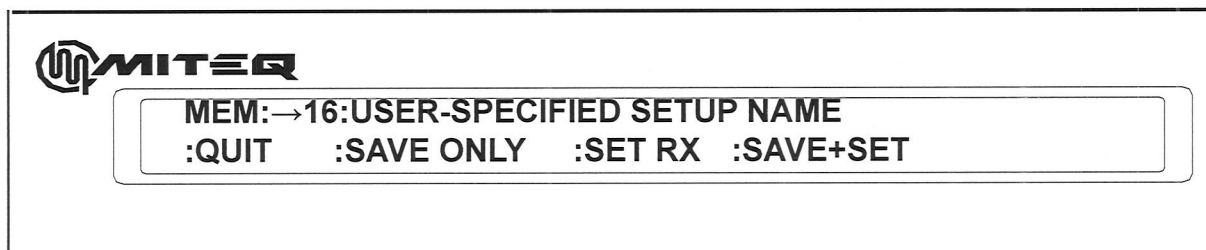

Figure 5-13. Memory Functions Menu Display #2

## **MEM: Memory Registers**

The user can store and recall a setup in each of the sixteen memory locations. To store the settings in memory of the unit:

1. Use the Up/Down arrow keys to choose a memory location.
2. Press the "CURSOR" key to highlight the memory name field. Use the Up/Down arrows to scroll through the character set. Use the "Cursor" key to choose the next character. Use the "ENT" key to terminate the name entry.
3. Press the "CURSOR" key to highlight the "REVIEW/CHANGE" field. Press the "ENT" key.
4. Use the "CURSOR" key to cycle through each of the fields that are stored in the memory location. The final screen of the memory menu will prompt to "QUIT", "SAVE", "SET" or "SAVE+SET" the parameters entered (See Figure 5-12).
5. When performing the Review/Change function of the memory register, the first parameter displayed on the bottom line of the display is the Input Frequency.
6. Use the numeric data entry keys to set the Input Frequency to be stored.
7. Press the "ENT" key when the Input Frequency entry is complete. Use the "CURSOR" key to advance to the IF Gain Control Mode field.
8. Use the arrow keys to display the IF Gain Control Mode.
9. Press the "ENT" key when the IF Gain Control Mode to be stored is displayed.
10. Press the "CURSOR" key to advance to the Hold Time field.
11. Use the arrow keys to display the Hold Time value.
12. Press the "ENT" key when the Hold Time value to be stored is displayed.
13. Press the "CURSOR" key to advance to the Minimum Tracking Voltage field.
14. Use the arrow keys to display the sign of the Minimum Tracking Voltage to be stored.
15. Use the numeric data entry keys to display the Minimum Tracking Voltage.
16. Press the "ENT" key when the Minimum Tracking Voltage value to be stored is displayed.
17. Press the "CURSOR" key to advance to the Reference Voltage field.
18. Use the arrow keys to display the sign of the Reference Voltage to be stored.
19. Use the numeric data entry keys to display the Reference Voltage.
20. Press the "ENT" key when the Reference Voltage value to be stored is displayed.
21. Press the "CURSOR" key to advance to the Maximum Tracking Voltage field.
22. Use the arrow keys to display the sign of the Maximum Tracking Voltage to be stored.
23. Use the numeric data entry keys to display the Maximum Tracking Voltage.
24. Press the "ENT" key when the Maximum Tracking Voltage value to be stored is displayed.
25. Press the "CURSOR" key to advance to the Reference Level field.
26. Use the numeric data entry keys to display the Reference Level.
27. Press the "ENT" key when the Reference Level to be stored is displayed.
28. Press the "CURSOR" key to advance to the IF Gain field.
29. Use the arrow keys to display the sign of the IF Gain value.
30. Use the numeric data entry keys to display the IF Gain value.
31. Press the "ENT" key when the IF Gain value to be stored is displayed.
32. Press the "CURSOR" key to advance to the RF Gain field.
33. Use the numeric data entry keys to display the RF Gain value.
34. Press the "ENT" key when the RF Gain value to be stored is displayed.
35. Press the "CURSOR" key to advance to the Slope field.
36. Use the arrow keys to display the Slope value.
37. Press the "ENT" key when the Slope value to be stored is displayed.
38. Press the "CURSOR" key to advance to the Acquisition Range field.
39. Use the arrow keys to display the Acquisition Range value.
40. Press the "ENT" key when the Acquisition Range to be stored is displayed.
41. Press the "CURSOR" key to advance to the Tracking Range field.
42. Use the arrow keys to display the Tracking Range value.
43. Press the "ENT" key when the Tracking Range to be stored is displayed.
44. Press the "CURSOR" key to advance to the Tuner Bandwidth field.
45. Use the arrow keys to display the Tuner Bandwidth value.
46. Press the "ENT" key when the Tuner Bandwidth to be stored is displayed.
47. Press the "CURSOR" key to advance to the Video Bandwidth field.
48. Use the arrow keys to display the Video Bandwidth value.
49. Press the "ENT" key when the Video Bandwidth to be stored is displayed.
50. Use the "CURSOR" key to choose to "QUIT", "SAVE ONLY", "SET RX", "MEASUREMENT MODE", "TOTAL/PEAK" or "SAVE+SET" the memory settings.

51. Quit will come back to the "REVIEW/CHANGE" memory settings without making any changes.
52. Save Only saves the settings in the memory register but does not affect the current receiver settings.
53. Set RX will set the receiver to the memory settings.
54. Save+Set will save and set the memory settings to the chosen memory register and will update the current receiver settings.

## REMOTE INTERFACE MENU

The Remote Operation Menu allows the operator to configure the remote control parameters and to switch the unit between remote and local control. The following parameters are accessible from the remote operations menu:

- Control - Remote/Local
- Bus: Bus selection (RS485/RS422 standard configuration)
- Bus: Bus selection (RS232 option 17C configuration only)
- Remote Address
- Baud Rate
- Parity

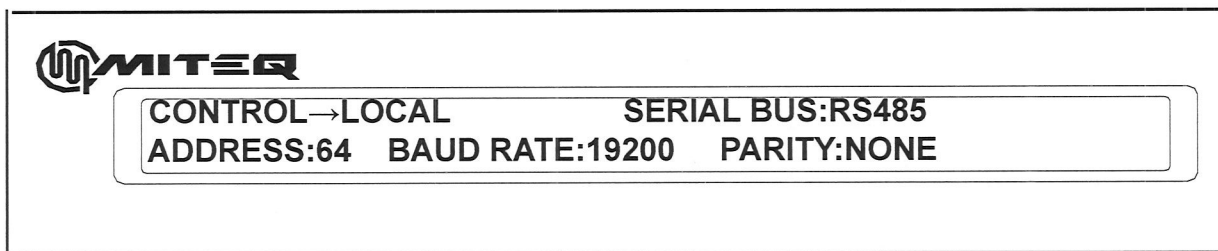

**Figure 5-14. RS485 Display Lines 1 and 2**

### Control: Remote/Local Control

The "REMOTE" LED is lit when the converter is under remote control. The LED is extinguished when the converter is under local control. To toggle between local and remote control:

- Press the "CURSOR" key to highlight the control field on the display.
- Use the up and down arrow keys to toggle the display between "REMOTE" and "LOCAL".
- Press "ENTER" to activate the displayed state.

If "ENT" is not pressed after five seconds the entry will expire and the display will revert to the original state.

### BUS: Remote Interface Bus

In standard units the user can select either RS485 or RS422. To toggle the Remote Interface Bus between RS485 and RS422:

- Press the "CURSOR" key to highlight the Remote Interface Bus field on the display.
- Use the up and down arrow keys to scroll through the available options until the desired setting is displayed.
- Press "ENTER" to save the selection.

If "ENT" is not pressed after five seconds the entry will expire and the display will revert to the original state.

**Note** *In units supplied with Option 17C the only remote interface bus choice is RS232.*

### Address: Remote Address

The unit can occupy a remote address from 64 to 95. To select the Remote Address:

- Press the "CURSOR" key to highlight the address field on the display.
- Use the numeric data entry keys to enter the desired address or the up and down arrow keys to increment or decrement the displayed address respectively.
- If the numeric data entry keys were used, press "ENT" to save the address.

If "ENT" is not pressed after five seconds the entry will expire and the display will revert to the original address.

### Baud Rate

To select the Baud Rate of the serial port:

- Press the "CURSOR" key to highlight the Baud Rate field on the display.

- Use the up and down arrow keys to scroll through the available options until the desired setting is displayed. The baud rates available are 1200, 2400, 4800, 9600, 19200 and 38400.
- Press "ENT" to save the selection.

If "ENT" is not pressed after five seconds the entry will expire and the display will revert to the original baud rate.

### Parity

To select the Parity for remote communications:

- Press the "CURSOR" key to highlight the parity field on the display.
- Use the up and down arrow keys to scroll through the available options until the desired setting is displayed. The parity can be set to ODD, EVEN, or NONE.
- Press "ENT" to save the selection.

If "ENT" is not pressed after five seconds the entry will expire and the display will revert to the original parity.

## ETHERNET CONFIGURATION MENU

The Ethernet Configuration screen allows the operator to configure the Ethernet setting listed below. These are presented in two consecutive screens:

- Static Dynamic IP Address (DHCP)
- Ethernet IP Address
- Ethernet Subnet Mask
- Ethernet Gateway
- Ethernet Password

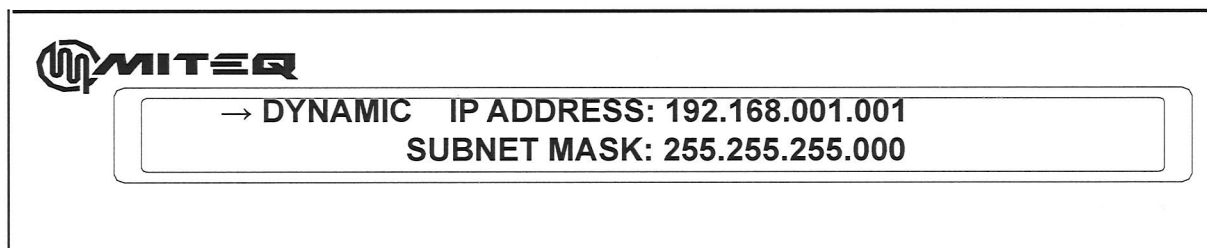

**Figure 5-15. Ethernet Configuration Menu Display #1**

- Use the arrow keys to choose Static or Dynamic (DHCP) address.
- Press "ENT" to save the selection.
- Use the numeric keys to display the desired IP address.
- Press "ENT" to save the selection.
- Use the "CURSOR" key to move to the next field with the Subnet Mask.
- Use the numeric keys to display the desired Subnet Mask.
- Press "ENT" to save the selection.
- Use the "CURSOR" key to move the next screen with the IP Gateway and Password.

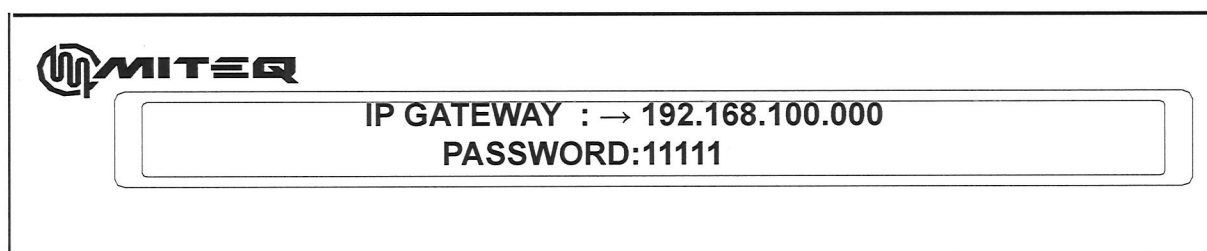

**Figure 5-16. Ethernet Configuration Menu Display #2**

- Use the "CURSOR" key to move to the IP Gateway field.
- Use the numeric keys to display the desired IP Gateway.
- Press "ENT" to save the selection.

- Press the “CURSOR” key to highlight the Password field.
- Use the numeric keys to enter the Ethernet password or use the arrow keys to disable the password.
- Press “ENT” to save the selection.

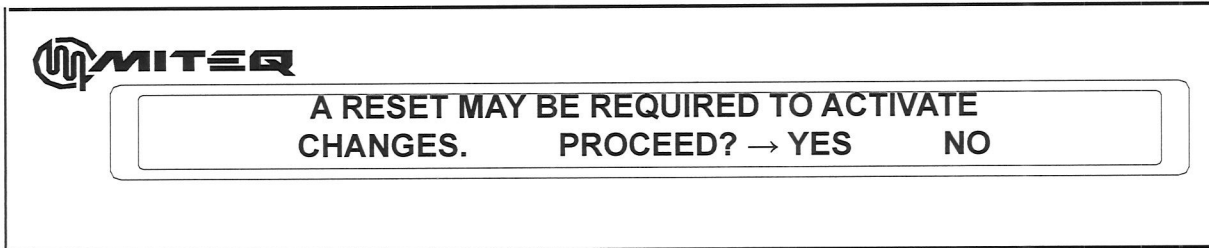
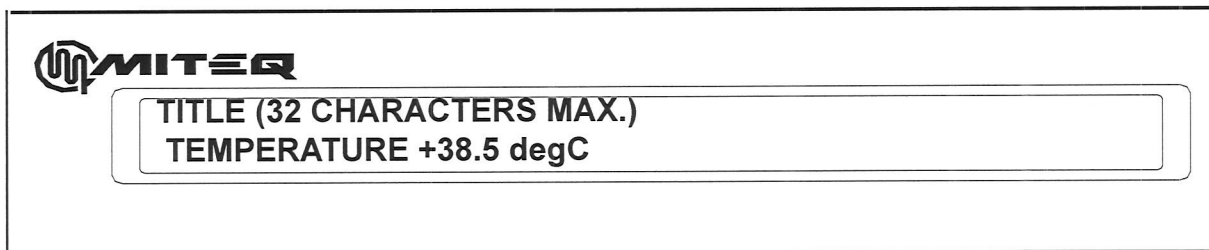

**Figure 5-17. Final Ethernet Configuration Menu Display**

Use the “CURSOR” key to move to the final Ethernet configuration menu screen to update and save current Ethernet selections or to Quit and not accept any of the changes.

## RECEIVER TITLE MENU

This menu displays the beacon receiver title and the chassis temperature in degree C.



**Figure 5-18. Receiver Title Menu Display**

### To Enter a Receiver Title

- Press the “CURSOR” key to position the cursor on the first character in the Receiver Title.
- Use the arrow keys to scroll through the available characters until the desired character is highlighted.
- Press the “CURSOR” key to advance to the next character position.
- Press the “ENT” key to store the Receiver Title.

## UTILITY MENU

The utility menu allows the operator to enter the correct date and time as well as adjust the contrast of the LCD.

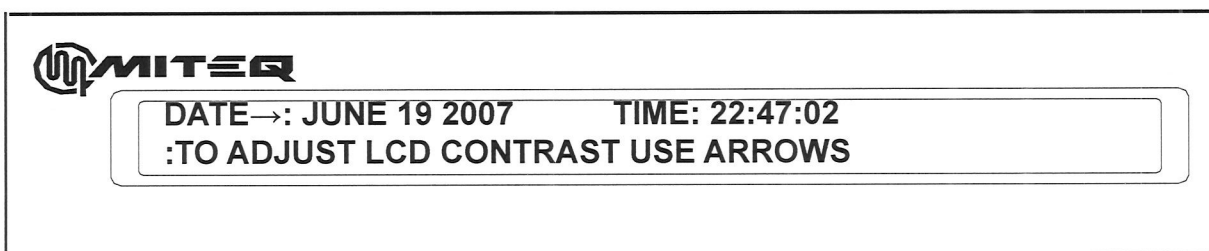

**Figure 5-19. Utility Menu Display**

### Date and Time

In order to adjust the Date and Time:

- Press the “CURSOR” key to select each of the fields: month, day, year, hour, minute, second.
- If the highlighted field is correct then press the “CURSOR” key to advance to the next field.



- If the highlighted field needs adjustment use the arrow keys or the numeric data entry keys to adjust the new display.
- Continue to press the "CURSOR" key adjusting the necessary fields until all of the fields are correct.
- Press "ENT" to save the date and time.

If "ENT" is not pressed after five seconds the entry will expire and the display will revert to the original setting.

#### LCD Contrast

In order to adjust the LCD Contrast:

- Without pressing the "CURSOR" key use the up arrow key to darken the display. Use the down arrow key to lighten the display. The setting is automatically saved. There is no need to press "ENT."

### RECEIVER REVISION DISPLAY

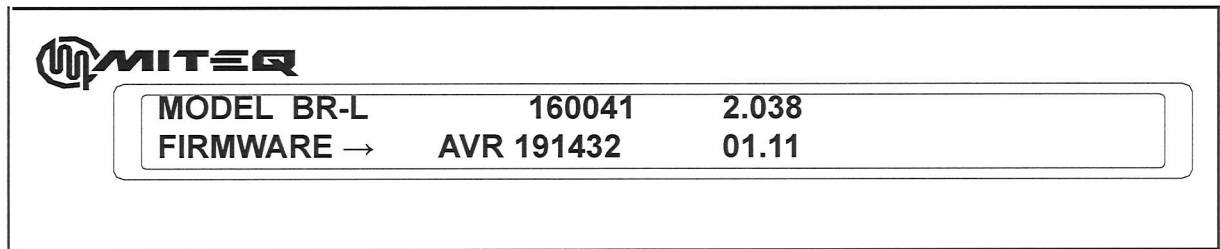

**Figure 5-20. Receiver Revision Display**

This screen contains the firmware revision control information for the Beacon Receiver unit. The information contained on this screen is informational only and cannot be edited by the user.

- Use the arrow keys to view the MITEQ firmware document number and revision of the AVR or the Cold-fire devices in the receiver.

## REMOTE OPERATIONS

The equipment is supplied with an RS485/RS422 bus interface and an Ethernet interface.

### SERIAL REMOTE PROTOCOL (RS485/RS422/RS232)

The standard Beacon Receiver ships with RS485 and RS422 capability. When Option 17C is chosen, the Beacon Receiver communications port is configured for RS232 only.

The command structures for the serial buses RS485, RS422 and RS232 are identical. All transmissions are multi-byte sequences beginning with a header byte and ending with a trailer byte and checksum byte. The transmitted bytes are all ASCII printable characters in the range of 20H to 7EH.

Serial data format is a 10-bit sequence consisting of either 1 Start, 7 Data, 1 Parity, and 1 Stop bit or 1 Start, 8 Data, 0 Parity (No Parity) and 1 Stop bit. All characters, including the checksum character, are checked for parity. If any character in a command message contains an error (parity, framing, or overrun) or the checksum is incorrect, the command is ignored and an error code response is returned. The remote parameters Address, Baud Rate, and Parity, are programmable from the front panel. The response time from command to acknowledge is 100 ms. maximum.

All messages addressed to the equipment are acknowledged with a response message. The unit continually monitors the communication bus and will accept commands, addressed to it, even in Local mode. When in Local mode, receipt of any SET commands (commands beginning with "\$") will be ignored and the unit will respond with an error code.

The response time from command to acknowledge is 100 ms. maximum. Since all bytes are ASCII printable characters, a compatible terminal may be used to control the equipment or monitor traffic on the communication bus.

### SERIAL MESSAGE FORMAT

The serial message format is as follows:

HEADER - ADDRESS - COMMAND/ERROR CODE - PARAMETERS -  
TRAILER - CHECKSUM

The Header byte is 7BH, ASCII character "{".

The address may take on the values from 64 to 95 decimal (40H to 5FH).

Commands are three ASCII characters preceded by an ASCII "?" or "\$". Commands preceded by "?" are QUERY commands and those preceded by "\$" are SET commands. Query commands are used to examine system parameters while SET commands are intended to modify system parameters.

Parameters are all ASCII printable characters in the range of 20H to 7EH. Numeric parameters are sent MSD first, LSD last. Values which do not adhere to the command format, or are beyond the allowable range, will be rejected and cause the unit to respond with an error code.

The Trailer byte is 7DH, ASCII character "}".

The checksum byte is the sum modulo 95 of all message characters beginning with the header byte up to and including the trailer byte. The value 32 is subtracted from each character value before taking the modulo 95 sum. The value 32 is added to the final sum to obtain the checksum value. All values are in decimal.

$$\text{Checksum} = \text{MOD} [(\text{character value} - 32), 95] + 32$$

Below is a program, written in the 'C' programming language that illustrates the checksum calculation.

```
char check_sum(char*,char);

char check_sum(array,mes_len)
/* return the checksum character for the message in array */
/* subtract 32 from each character before taking modulo 95 sum */
/* add 32 to the final sum */
/* mes_len = message length */
char array[32],mes_len;

{
char i,sum;
    sum = 0;
    for ( i = 0; i < mes_len; i++ ) {
        sum = sum + ( array[i] - 32 );
        if ( sum >= 95 ) sum = sum - 95;
    }
    return(sum + 32);
}
```

## COMMAND CODE SUMMARY

The following paragraphs describe each of the command codes. Commands preceded by “?” are QUERY commands and those preceded by “\$” are SET commands. QUERY commands are used to examine system parameters while SET commands are intended to modify system parameters.

COMMAND CODES	
ASCII Character String	Function
AGC	IF Gain Control Mode
ALR	Alarm Status
AQR	Acquisition Range
BWC	Backward Compatibility Mode
CFG	Configure from Memory
CLK	Internal Calendar/Clock
DEL	Delta Signal Level
EAD	All Ethernet Parameters
FRQ	Input Frequency
HOL	Output Hold-time
LOG	Beacon Receiver Event Log Entries
MEM	Memory Register Store/Recall
MMD	Measurement Mode
MNV	Minimum Voltage
MOD	Model
MVL	IF Gain
MXV	Maximum Voltage
OFF	Frequency Offset
OUT	Output Voltage
PWD	Ethernet Password
PWR	Signal Strength
REF	Reference Level
REM	Remote/Local Control Mode
RFG	RF Gain
RFL	RF Level
RFV	Reference Voltage
RTL	Receiver Title
SET	Memory Register Store/Recall and Set
SLP	Output Slope
SNR	Signal to Noise Ratio
TBW	Tuner Bandwidth
TMP	Chassis Temperature
TRK	Tracking Range
VBW	Video Bandwidth
VER	Firmware Revision
VLT	System Voltages
XRF	External Reference

ERROR CODES (SERIAL PROTOCOL ONLY)	
ASCII Character	Function
a	Command not recognized
b	Illegal parameter or parameter out of range
c	Unit in Local mode
d	Busy

## IF GAIN CONTROL MODE = AGC

The SET command requires one single character parameter representing the IF Gain Control Mode.

Command	Parameters
Remote Command Sequence:	\$AGCg
Unit Response:	\$AGC

The QUERY command requires no parameters. The reply will consist of one character indicating the IF Gain Control Mode.

Command	Parameters
Remote Command Sequence:	?AGC
Unit Response:	?AGCg
	AGC: IF Gain Control Mode indicator g: Single ASCII numeric character 0 = Manual 1 = Automatic

## SYSTEM FAULT STATUS = ALR

The SET command requires one parameter to set/clear a user-generated test alarm.

Command	Parameters
Remote Command Sequence:	\$ALRn
Unit Response:	\$ALR
	ALR: Alarm indicator n: "0" or "1" ASCII character 0 = Clear 1 = Set

The QUERY command requires no parameters.

Command	Parameters
Remote Command Sequence:	?ALR
Unit Response:	?ALRabcdefghijklmn
	<p>?ALR: Component Fault Status indicator            a-i: "0" or "1" ASCII numeric character                0 = No fault                1 = Fault</p> <p>a-i indicates the status of the component faults described below.</p> <ul style="list-style-type: none"> <li>a Receiver Lock Alarm</li> <li>b Local Oscillator Alarm</li> <li>c Input Level Low</li> <li>d Input Level High</li> <li>e RF Over-range</li> <li>f Power Supply 15V</li> <li>g Power Supply 5V</li> <li>h Power Supply 3.3V</li> <li>i Power Supply 1.8V</li> <li>j Power Supply 1.6V</li> <li>k Power Supply -15V</li> <li>l RF Calibration Error</li> <li>m IF Over-range</li> <li>n Test Alarm</li> </ul>

## ACQUISITION RANGE = AQR

The SET command requires one three-character parameter representing the Acquisition Range in kHz.

Command	Parameters
Remote Command Sequence:	\$AQRrrr
Unit Response:	\$AQR

The QUERY command requires no parameters. The reply will consist of three characters indicating the Acquisition Range in kHz.

Command	Parameters
Remote Command Sequence:	?AQR
Unit Response:	?AQRrrr
	<p>AQR: Acquisition Range indicator            rrr: Three ASCII characters, MSD transmitted first, LSD last            Indicating Acquisition Range in kHz.</p> <p>The possible values for the Acquisition Range parameter are:</p> <ul style="list-style-type: none"> <li>000.....1 TBW (7.5, 150, 300 kHz)</li> <li>010.....10 kHz</li> <li>020.....20 kHz</li> <li>050.....50 kHz</li> <li>100.....100 kHz</li> <li>200.....200 kHz</li> <li>500.....500 kHz</li> <li>700.....700 kHz</li> </ul>

## BACKWARD COMPATIBILITY MODE = BWC

The SET command requires one single character parameter representing the Backward Compatibility Mode

Command	Parameters
Remote Command Sequence:	\$BWCn
Unit Response:	\$BWC

The QUERY command requires no parameters. The reply will consist of one character indicating the Backward Compatibility Mode

Command	Parameters
Remote Command Sequence:	?BWC
Unit Response:	?BWCn
	BWC: Backward Compatibility indicator n: Single ASCII numeric character, 1 = Frequency in MHz, Offset in kHz 2 = Frequency in Hz, Offset in Hz

## CONFIGURE FROM MEMORY = CFG

The SET only command configures the Beacon Receiver from the specified memory register.

Command	Parameters
Remote Command Sequence:	\$CFGrr
Unit Response:	\$CFG
	rr: Two-digit ASCII numeric characters, 01 to 16, indicating the Memory Register being accessed

## INTERNAL CALENDAR/CLOCK = CLK

The SET command requires a twenty-character parameter that sets the date and time of the Internal Calendar/Clock.

Command	Parameters
Remote Command Sequence:	\$CLKYyyyMmmDddHhhNnnSss
Unit Response:	\$CLK

The QUERY command requires no parameters.

Command	Parameters
Remote Command Sequence:	?CLK
Unit Response:	?CLKYyyyMmmDddHhhNnnSss
	<p>Y: Year indicator            yyyy: Year, Four-digit ASCII numeric characters, MSD transmitted first, LSD last.</p> <p>M: Month indicator            mm: Month, Two-digit ASCII numeric characters</p> <p>D: Day indicator            dd: Day, Two-digit ASCII numeric characters</p> <p>H: Hour indicator            hh: Hour, Two-digit ASCII numeric characters</p> <p>N: Minute indicator            nn: Minute, Two-digit ASCII numeric characters</p> <p>S: Second indicator            ss: Second, Two-digit ASCII numeric characters</p>

## DELTA SIGNAL LEVEL = DEL

There is no SET command.

The QUERY command requires no parameters

Command	Parameters
Remote Command Sequence:	?DEL
Unit Response:	?DELSrr.rr
	srr.rr: sign and a six-digit ASCII numeric characters



## SET ALL ETHERNET PARAMETERS = EAD

The SET command requires three 12-digit parameters indicating the Ethernet IP address, Ethernet gateway and the Ethernet subnet mask of the Beacon Receiver control unit.

Command	Parameters
Remote Command Sequence:	\$EADliiiiiiiiiiGgggggggggggSsssssssssss
Unit Response:	\$EAD

The QUERY command requires no parameters.

Command	Parameters
Remote Command Sequence:	?EAD
Unit Response:	?EADliiiiiiiiiiGgggggggggggSsssssssssss
	<p>EAD: Ethernet Address indicator. If the indicator is capitalized in the remote response, then the IP address that was set is a Static IP address. If the indicator is in lower case letters then the IP address is a Dynamic IP address and was obtained using DHCP (Dynamic Host Configuration Protocol) server to assign the IP address.</p> <p>I: Ethernet IP Address parameter indicator            iiiiiiiiii: Twelve-digit ASCII numeric characters,            ***** = no change to stored value in position            000000000000 = get DHCP address</p> <p>G: Ethernet gateway parameter indicator            gggggggggggg: Twelve-digit ASCII numeric characters,            ***** = no change to stored value in position            000000000000 = get DHCP address</p> <p>S: Ethernet Subnet mask parameter indicator            ssssssssssss: Twelve-digit ASCII numeric characters,            ***** = no change to stored value in position            000000000000 = get DHCP address</p>

## INPUT FREQUENCY = FRQ

The Frequency command format is dependent on the Backward Compatibility setting of the unit. If the unit is in the standard mode (?BWC = 2), the frequency form is in Hz. Use the ten-character frequency format. If the unit is configured to be in the backward compatibility mode (?BWC = 1), the frequency format is in MHz. Use the seven-character frequency format.

### STANDARD MODE FREQUENCY COMMAND

The SET command requires one ten-character parameter representing the Input Frequency in Hz.

Command	Parameters
Remote Command Sequence:	\$FRQxxxxxxxx
Unit Response:	\$FRQ

The QUERY command requires no parameters. The reply will consist of ten characters indicating Input Frequency in Hz.

Command	Parameters
Remote Command Sequence:	?FRQ
Unit Response:	?FRQxxxxxxxx
	xxxxxxxx: Ten ASCII numeric characters, MSD transmitted first, LSD last. Indicating Input Frequency in Hz.  The possible values for the Input Frequency parameter are within the range of: 0940000000 to 2150000000

### BACKWARD COMPATIBILITY MODE

The SET command requires one seven-character parameter representing the Input Frequency in kHz.

Command	Parameters
Remote Command Sequence:	\$FRQxxxxxx
Unit Response:	\$FRQ

The QUERY command requires no parameters. The reply will consist of seven characters indicating Input Frequency in kHz.

Command	Parameters
Remote Command Sequence:	?FRQ
Unit Response:	?FRQxxxxxx
	xxxxxx: Seven ASCII numeric characters, MSD transmitted first, LSD last. Indicating Input Frequency in kHz.  The possible values for the Input Frequency parameter are within the range of: 0940000 to 2150000

## OUTPUT HOLD TIME = HOL

The SET command requires one four-digit parameter representing the Hold time in seconds.

Command	Parameters
Remote Command Sequence:	\$HOLwww
Unit Response:	\$HOL

The QUERY command requires no parameters. The reply will consist of four characters indicating Hold time.

Command	Parameters
Remote Command Sequence:	?HOL
Unit Response:	?HOLwww
	<p>HOL: Holdtime indicator www: Four-digit ASCII characters, MSD transmitted first, LSD last. Indicating Holdtime</p> <p>The possible values for the Holdtime parameter are:</p> <ul style="list-style-type: none"><li>0000.....0 sec</li><li>0001.....1 sec</li><li>0002.....2 sec</li><li>0005.....5 sec</li><li>0010.....10 sec</li><li>0015.....15 sec</li><li>0030.....30 sec</li><li>0060.....60 sec</li><li>0120.....120 sec</li><li>0300.....300 sec</li><li>0600.....600 sec</li></ul>

## RECEIVER EVENT LOG ENTRIES = LOG

The SET only command clears the Beacon Receiver event log of its contents.

Command	Parameters
Remote Command Sequence:	\$LOG00
Unit Response:	\$LOG

The QUERY command requires a two-digit parameter indicating the log entry to be examined. If entry 00 is queried, the unit returns the number of log entries currently in the log, otherwise the unit responds with the date, time and a code indicating the event which has occurred.

Command	Parameters
Remote Command Sequence:	?LOGnn
Unit Response:	?LOGnnCyyyymmddhhnnssEeee
	<p>nn: Two-digit ASCII numeric characters, MSD transmitted first, LSD last, indicating the log entry queried. (If '00' was sent to the Beacon Receiver then '00' through '64' is returned indicating the number of log entries that are stored.)</p> <p>C: Calendar/Clock indicator.</p> <p>yyyy: Year, Four-digit ASCII numeric characters, MSD transmitted first, LSD last.</p> <p>mm: Month, Two-digit ASCII numeric characters</p> <p>dd: Day, Two-digit ASCII numeric characters</p> <p>hh: Hour, Two-digit ASCII numeric characters</p> <p>nn: Minute, Two-digit ASCII numeric characters</p> <p>ss: Second, Two-digit ASCII numeric characters</p> <p>E: Alarm indicator.</p> <p>eee: Event Code 001 to 255 represents the following:</p>

Event Indicator	Event
01	Beacon Receiver startup
02	Loss Of Lock
03	Lock Acquisition
04	Local Oscillator Lock fault
05	Local Oscillator Lock fault recovery
06	Input Signal Level Low warning
07	Input Signal Level Low warning recovery
08	Input Signal Level High warning
09	Input Signal Level High warning recovery
10	RF Over-range
11	RF Over-range recovery
12	+15V power supply fault
13	+15V power supply fault recovery
14	+5V power supply fault
15	+5V power supply fault recovery
16	+3.3V power supply fault

Event Indicator	Event
17	+3.3V power supply fault recovery
18	+1.8V power supply fault
19	+1.8V power supply fault recovery
20	+1.6V power supply fault
21	+1.6V power supply fault recovery
22	-15V power supply fault
23	-15V power supply fault recovery
24	RF Calibration Error
25	Event log cleared
26	IF Over-range
27	IF Over-range recovery
28	User-programmable Test Alarm
29	User-programmable Test Alarm recovery
30	DSP communication error
31	DSP fatal error
32	External Reference Change
33	Control Mode Change
34	AFC Communication Error
35	AVR Program Error
36	CF Bus Error
37	DSP Handshake Error
38	CF Address Error
39	CF Instruction Error
40	CF Divide by 0 Error
41	CF Privilege Error
42	CF Instruction Format Error
43	CF Undefined Interrupt Error





U: Tuner Bandwidth Indicator (TBW)  
uuu.u: Five digit ASCII numeric characters,  
MSD transmitted first, LSD last indicating Tuner Bandwidth in kHz.

007.5.....7.5 kHz  
150.0.....150 kHz  
340.0.....340 kHz

V: Video Bandwidth Indicator (VBW)  
vv.v: Four digit ASCII numeric characters,  
MSD transmitted first, LSD last indicating Video Bandwidth in Hz.

00.1.....0.1 Hz  
00.2.....0.2 Hz  
00.5.....0.5 Hz  
01.0.....1.0 Hz  
02.0.....2.0 Hz  
05.0.....5.0 Hz  
10.0.....10.0 Hz

M: Minimum Voltage Indicator (MNV)  
s: "+" or "-" indicating sign  
mm.m: Four digit ASCII numeric characters  
indicating the Minimum Voltage in volts.

R: Reference Voltage Indicator (RFV)  
s: "+" or "-" indicating sign  
rr.r: Four digit ASCII numeric characters indicating the Reference Voltage in volts.

X: Maximum Voltage Indicator (MXV)  
s: "+" or "-" indicating sign  
xx.x: Four digit ASCII numeric characters indicating the Maximum Voltage in volts.

S: Slope Indicator (SLP)  
s: "+" or "-" indicating sign  
nn.n: Four digit ASCII numeric characters indicating the Output Slope in dB/Volts.

-10.0.....-10.0 dB/Volt  
-08.0.....-8.0 dB/Volt  
-06.0.....-6.0 dB/Volt  
-04.0.....-4.0 dB/Volt  
-02.0.....-2.0 dB/Volt  
-01.0.....-1.0 dB/Volt  
-00.5.....-0.5 dB/Volt  
+00.5.....+0.5 dB/Volt  
+01.0.....+1.0 dB/Volt  
+02.0.....+2.0 dB/Volt  
+04.0.....+4.0 dB/Volt  
+06.0.....+6.0 dB/Volt  
+08.0.....+8.0 dB/Volt  
+10.0.....+10.0 dB/Volt



	<p>H: Hold time Indicator (HOL)  hhh: Four-digit ASCII numeric characters, MSD transmitted first, LSD last indicating Holdtime in Secs.  0000.....0 sec  0001.....1 sec  0002.....2 sec  0005.....5 sec  0010.....10 sec  0015.....15 sec  0030.....30 sec  0060.....60 sec  0120.....120 sec  0300.....300 sec  0600.....600 sec</p> <p>P: Power Indicator (REF)  s: "-" indicating sign  ppp.p: Five digit ASCII numeric characters, MSD transmitted first, LSD last indicating Reference Level in dBm.</p> <p>N: IF Gain Indicator (MVL)  s: "-" indicating sign  kk.k: Four digit ASCII numeric characters, MSD transmitted first, LSD last indicating IF Gain in dB.</p> <p>G: RF Gain Indicator (RFG)  s: "-" indicating sign  gg.g: Four digit ASCII numeric characters, MSD transmitted first, LSD last indicating RF Gain in dB.</p> <p>D: Measurement Mode Indicator  d: Single ASCII numeric character,  0 = Peak,  1 = Total.</p>
--	---

## MEASUREMENT MODE = MMD

The SET command requires one single-character parameter representing the Measurement Mode.

Command	Parameters
Remote Command Sequence:	\$MMDg
Unit Response:	\$MMD
	MMD: Measurement Mode indicator g: Single ASCII numeric character 0 = Peak 1 = Total

The QUERY command requires no parameters. The reply will consist of one character indicating the Measurement Mode.

Command	Parameters
Remote Command Sequence:	?MMD
Unit Response:	?MMDg
	MMD: Measurement Mode indicator g: Single ASCII numeric character 0 = Peak 1 = Total

## MINIMUM VOLTAGE = MNV

The SET command requires a five-character parameter indicating the Minimum Voltage.

Command	Parameters
Remote Command Sequence:	\$MNVsvv.v
Unit Response:	\$MNV

The QUERY command requires no parameters.

Command	Parameters
Remote Command Sequence:	?MNV
Unit Response:	?MNVsvv.v
	MNV: Minimum Voltage indicator s: "+" or "-" indicating sign mm.m: Four digit ASCII numeric characters indicating the Minimum Voltage in volts.  The possible values for the Minimum Voltage parameter are: -10.0 to RFV

## MODEL = MOD

There is no SET command.

The QUERY command requires no parameters.

Command	Parameters
Remote Command Sequence:	?MOD
Unit Response:	?MODnnnnnnnnnn
	MOD: Receiver Model Number indicator nnnnnnnnnn: 16 character model number

## IF GAIN = MVL

The SET command requires one five-character parameter representing the IF Gain in dB. The first character of the parameter is a sign, the fourth character is a decimal point. The value of IF Gain that is set is only valid when the AGC mode is in manual.

Command	Parameters
Remote Command Sequence:	\$MVLsvv.v
Unit Response:	\$MVL

The QUERY command requires no parameters. The reply will consist of one five-character parameter representing IF Gain in dB at the Manual AGC setting. The first character of the parameter is a minus sign, the fourth character is a decimal point. The value returned will be the value of IF Gain when the AGC mode is set to 'MANUAL' mode.

Command	Parameters
Remote Command Sequence:	?MVL
Unit Response:	?MVLsvv.v
	MVL: IF Gain indicator s: "+" or "-" indicating sign vv.v: Four digit ASCII numeric characters, MSD transmitted first, LSD last. Indicating the IF Gain in dB.  The possible values for the IF Gain parameter are: -10.0 to +45.0

## MAXIMUM VOLTAGE = MXV

The SET command requires a five-character parameter indicating the Maximum Voltage.

Command	Parameters
Remote Command Sequence:	\$MXVsvv.v
Unit Response:	\$MXV

The QUERY command requires no parameters.

Command	Parameters
Remote Command Sequence:	?MXV
Unit Response:	?MXVsvv.v
	MXV: Maximum Voltage indicator s: "+" or "-" indicating sign mm.m: Four digit ASCII numeric characters indicating the Maximum Voltage in volts.  The possible values for the Maximum Voltage parameter are: RFV to +10.0

## FREQUENCY OFFSET = OFF

There is no SET command

### STANDARD MODE

Note that in the standard mode (?BWC = 2), the frequency is in Hz and uses the eight-character format.

The QUERY command requires no parameters. The reply will consist of eight characters indicating Frequency Offset in Hz.

Command	Parameters
Remote Command Sequence:	?OFF
Unit Response:	?OFFsffffff
	OFF: Frequency Offset indicator s: "+" or "-" indicating sign ffffff: Seven ASCII numeric characters indicating Frequency Offset in Hz.

### BACKWARD COMPATIBLE MODE

Note that in the backward compatible mode (?BWC = 1), the frequency is in MHz and uses the six-character format.

The QUERY command requires no parameters. The reply will consist of six characters indicating Frequency Offset in kHz.

Command	Parameters
Remote Command Sequence:	?OFF
Unit Response:	?OFFsfff.f
	OFF: Frequency Offset indicator s: "+" or "-" indicating sign fff.f: Five ASCII numeric characters indicating Frequency Offset in kHz.

## OUTPUT VOLTAGE = OUT

There is no SET command

The QUERY command requires no parameters. The reply will consist of six characters indicating Output Voltage in Volts.

Command	Parameters
Remote Command Sequence:	?OUT
Unit Response:	?OUTsff.ff
	OUT: Output Voltage indicator s: "+" or "-" indicating sign ff.ff: Five digit ASCII numeric characters, MSD transmitted first, LSD last. Indicating Output Voltage in Volts.

## ETHERNET PASSWORD = PWD

The SET command requires two five-digit parameters. The first five are the old password and the second five indicate the new password. If the Old password is incorrect, the command will be rejected..

Command	Parameters
Remote Command Sequence:	\$PWDpppppnnnnn
Unit Response:	\$PWD

The QUERY command requires no parameters.

Command	Parameters
Remote Command Sequence:	?PWD
Unit Response:	?PWDppppp
	ppppp: existing password (0 to 9) for each digit in ASCII numeric characters. nnnnn: new password (0 to 9) for each digit in ASCII numeric characters. If the password has been disabled, then it will be displayed as DISAB

## SIGNAL STRENGTH = PWR

There is no SET command.

The QUERY command requires no parameters. The reply will contain a seven-character parameter. The first character is a minus sign, the next to last character in each parameter is a decimal point. The units are Signal Strength in dBm.

Command	Parameters
Remote Command Sequence:	?PWR
Unit Response:	?PWRsppp.pp
	PWR: Signal Strength indicator s: "-" indicating sign ppp.pp: Six-digit ASCII numeric characters, MSD transmitted first, LSD last. Indicating measured Signal Strength in dBm.

## REFERENCE LEVEL = REF

The SET command can include a five-character parameter representing the Reference Level in dBm. The first character of the parameter is a minus sign, the fourth character is a decimal point. If the parameter is not included, the prevailing Measured Power is stored as the Reference Level.

Command	Parameters
Remote Command Sequence:	\$REFsppp.p
Unit Response:	\$REF

The QUERY command requires no parameters. The reply will consist of one six-character ASCII numeric parameter representing Reference Level in dBm. The first character of the parameter is a minus sign, the fourth character is a decimal point.

Command	Parameters
Remote Command Sequence:	?REF
Unit Response:	?REFsppp.p
	REF: Reference Level indicator s: "-" indicating sign ppp.p: Five-digit ASCII numeric characters, MSD transmitted first, LSD last. Indicating measured Signal Strength in dBm.

## REMOTE/LOCAL CONTROL MODE = REM

There is no SET command. If the unit is in local mode, settings can be queried from the units remote ports but no parameters can be changed remotely. This applies to RS485/422 and all operations using the Ethernet port.

The QUERY command requires no parameters.

Command	Parameters
Remote Command Sequence:	?REM
Unit Response:	?REMr
	r: "0" or "1" ASCII numeric character 0 = Local control mode 1 = Remote control mode

## RF GAIN = RFG

The SET command requires one five-character parameter representing the RF Gain in dB. The first character of the parameter is a sign, the fourth character is a decimal point.

Command	Parameters
Remote Command Sequence:	\$RFGsv.v
Unit Response:	\$RFG

The QUERY command requires no parameters. The reply will consist of one five-character parameter representing RF Gain in dB. The first character of the parameter is a minus sign, the fourth character is a decimal point.

Command	Parameters
Remote Command Sequence:	?RFG
Unit Response:	?RFGsv.v
	RFG: RF Gain indicator s: "+" or "-" indicating sign vv.v: Four digit ASCII numeric characters, MSD transmitted first, LSD last. Indicating the RF Gain in dB.  The possible values for the RF Gain parameter are: +10.0 to +60.0

## RF SIGNAL LEVEL = RFL

There is no SET command.

The QUERY command requires no parameters. The reply will contain a six-character parameter. The first character is a less than sign, the next to last character in each parameter is a decimal point. The units are Signal Strength in dBm. The detectable limit is -60.0 dBm.

Command	Parameters
Remote Command Sequence:	?RFL
Unit Response:	?RFLxspp.p







	<p>SET: Unit Memory Register Store/Recall and SET indicator rr: Two-digit ASCII numeric characters, indicating the memory register accessed.</p> <p>nnnnnnnnnnnnnnnnnnnnnnnnnnnnnnnnnnnn: 32-character Setup Name parameter that can be included with the SET command.</p> <p>nnnnnnnnnnnnnnnnnnnnnnnnnnnnnnnnnnnn: Thirty-two-character Setup Name parameter reported with the reply to the QUERY command.</p> <p>F: Input Frequency indicator. fffffff: Ten-digit ASCII numeric characters.     Indicating the Input Frequency in kHz.</p> <p>A: IF Gain Control Mode Indicator (AGC) a: Single ASCII numeric character,    0 = Manual Gain Control (MGC).    1 = Automatic Gain Control (AGC).</p> <p>Q: Acquisition Range Indicator (AQR) qqq: Three ASCII numeric characters,      MSD transmitted first, LSD last indicating Acquisition Range in kHz.</p> <p>000.....1 TBW 010.....10 kHz 020.....20 kHz 050.....50 kHz 100.....100 kHz 200.....200 kHz 500.....500 kHz 700.....700 kHz</p> <p>T: Tracking Range Indicator (TRK) ttt: Three ASCII numeric characters,      MSD transmitted first, LSD last indicating Acquisition Range in kHz.</p> <p>010.....10 kHz 020.....20 kHz 050.....50 kHz 100.....100 kHz 200.....200 kHz 500.....500 kHz 700.....700 kHz</p> <p>U: Tuner Bandwidth Indicator (TBW) uuu.u: Five digit ASCII numeric characters,       MSD transmitted first, LSD last indicating Tuner Bandwidth in kHz.</p> <p>007.5.....7.5 kHz 150.0.....150 kHz 340.0.....340 kHz</p>
--	--

V: Video Bandwidth Indicator (VBW)

vv.v: Four digit ASCII numeric characters,  
MSD transmitted first, LSD last indicating Video Bandwidth in Hz.

00.1.....0.1 Hz

00.2.....0.2 Hz

00.5.....0.5 Hz

01.0.....1.0 Hz

02.0.....2.0 Hz

05.0.....5.0 Hz

10.0.....10.0 Hz

M: Minimum Voltage Indicator (MNV)

s: "+" or "-" indicating sign

mm.m: Four digit ASCII numeric characters  
indicating the Minimum Voltage in volts.

R: Reference Voltage Indicator (RFV)

s: "+" or "-" indicating sign

rr.r: Four digit ASCII numeric characters indicating the Reference Voltage in volts.

X: Maximum Voltage Indicator (MXV)

s: "+" or "-" indicating sign

xx.x: Four digit ASCII numeric characters indicating the Maximum Voltage in volts.

S: Slope Indicator (SLP)

s: "+" or "-" indicating sign

nn.n: Four digit ASCII numeric characters indicating the Output Slope in dB/Volts.

-10.0.....-10.0 dB/Volt

-08.0.....-8.0 dB/Volt

-06.0.....-6.0 dB/Volt

-04.0.....-4.0 dB/Volt

-02.0.....-2.0 dB/Volt

-01.0.....-1.0 dB/Volt

-00.5.....-0.5 dB/Volt

+00.5.....+0.5 dB/Volt

+01.0.....+1.0 dB/Volt

+02.0.....+2.0 dB/Volt

+04.0.....+4.0 dB/Volt

+06.0.....+6.0 dB/Volt

+08.0.....+8.0 dB/Volt

+10.0.....+10.0 dB/Volt

	<p>H: Hold time Indicator (HOL)  hhh: Four-digit ASCII numeric characters, MSD transmitted first, LSD last indicating Holdtime in Secs.  0000.....0 sec  0001.....1 sec  0002.....2 sec  0005.....5 sec  0010.....10 sec  0015.....15 sec  0030.....30 sec  0060.....60 sec  0120.....120 sec  0300.....300 sec  0600.....600 sec</p> <p>P: Power Indicator (REF)  s: "-" indicating sign  ppp.p: Five digit ASCII numeric characters, MSD transmitted first, LSD last indicating Reference Level in dBm.</p> <p>N: IF Gain Indicator (MVL)  s: "-" indicating sign  kk.k: Four digit ASCII numeric characters, MSD transmitted first, LSD last indicating IF Gain in dB.</p> <p>G: RF Gain Indicator (RFG)  s: "-" indicating sign  gg.g: Four digit ASCII numeric characters, MSD transmitted first, LSD last indicating RF Gain in dB.</p> <p>D: Measurement Mode Indicator  d: Single ASCII numeric character,  0 = Peak,  1 = Total.</p>
--	---

## OUTPUT SLOPE = SLP

The SET command requires a four-character parameter indicating the Output Slope in dB/Volt.

Command	Parameters
Remote Command Sequence:	\$SLPsvv.v
Unit Response:	\$SLP

The QUERY command requires no parameters.

Command	Parameters
Remote Command Sequence:	?SLP
Unit Response:	?SLPsvv.v
	<p>SLP: Output Slope Indicator  s: "+" or "-" indicating sign  vv.v: Four digit ASCII numeric characters indicating the Output Slope in dB/Volts.</p> <p>The possible values for the Output Slope are:</p> <ul style="list-style-type: none"> <li>-10.0.....-10.0 dB/Volt</li> <li>-08.0.....-8.0 dB/Volt</li> <li>-06.0.....-6.0 dB/Volt</li> <li>-04.0.....-4.0 dB/Volt</li> <li>-02.0.....-2.0 dB/Volt</li> <li>-01.0.....-1.0 dB/Volt</li> <li>-00.5.....-0.5 dB/Volt</li> <li>+00.5.....+0.5 dB/Volt</li> <li>+01.0.....+1.0 dB/Volt</li> <li>+02.0.....+2.0 dB/Volt</li> <li>+04.0.....+4.0 dB/Volt</li> <li>+06.0.....+6.0 dB/Volt</li> <li>+08.0.....+8.0 dB/Volt</li> <li>+10.0.....+10.0 dB/Volt</li> </ul>

## SIGNAL TO NOISE RATIO = SNR

There is no SET command.

The QUERY command requires no parameters. The reply will consist of five characters indicating Signal to Noise Ratio in dB.

Command	Parameters
Remote Command Sequence:	?SNR
Unit Response:	?SNRsf.f
	<p>SNR: Signal to Noise Ratio indicator  s: "+" or "-" indicating sign  ff.f: Four digit ASCII numeric characters, MSD transmitted first, LSD last.  Indicating Signal to Noise Ratio in dB.</p>

## TUNER BANDWIDTH = TBW

The SET command requires one five-character parameter representing the Tuner Bandwidth in kHz.

Command	Parameters
Remote Command Sequence:	\$TBWwww.w
Unit Response:	\$TBW

The QUERY command requires no parameters. The reply will consist of four characters indicating Tuner Bandwidth in kHz.

Command	Parameters
Remote Command Sequence:	?TBW
Unit Response:	?TBWwww.w
	<p>TBW: Tuner Bandwidth Indicator            www.w: Five digit ASCII numeric characters,            MSD transmitted first, LSD last indicating Tuner Bandwidth in kHz.</p> <p>The possible values for the Tuner Bandwidth parameters are:</p> <p>007.5.....7.5 kHz            150.0.....150 kHz            340.0.....340 kHz</p>

## TEMPERATURE = TMP

There is no SET command.

The QUERY command requires no parameters. It returns the chassis temperature in degrees C.

Command	Parameters
Remote Command Sequence:	?TMP
Unit Response:	?TMPstt.t
	<p>s: "+" or "-" indicating sign            tt.t Four-digit ASCII numeric characters indicating the chassis temperature.</p>

## TRACKING RANGE = TRK

The SET command requires a three-character parameter representing the Tracking Range in kHz.

Command	Parameters
Remote Command Sequence:	\$TRKwww
Unit Response:	\$TRK

The QUERY command requires no parameters. The reply will consist of three characters indicating Tracking Range in kHz.

Command	Parameters
Remote Command Sequence:	?TRK
Unit Response:	?TRKwww
	<p>TRK: Tracking Range Indicator            www: Three-digit ASCII numeric characters,            MSD transmitted first, LSD last indicating Tracking Range in kHz.</p> <p>The possible values for the Tracking Range parameters are:</p> <p>010.....10 kHz            020.....20 kHz            050.....50 kHz            100.....100 kHz            200.....200 kHz            500.....500 kHz            700.....700 kHz</p>

## VIDEO BANDWIDTH = VBW

The SET command requires one four-character parameter representing the Video Bandwidth in Hz.

Command	Parameters
Remote Command Sequence:	\$VBWww.w
Unit Response:	\$VBW

The QUERY command requires no parameters. The reply will consist of four ASCII numeric characters indicating Video Bandwidth in Hz.

Command	Parameters
Remote Command Sequence:	?VBW
Unit Response:	?VBWww.w
	<p>VBW: Video Bandwidth Indicator            ww.w: Four-digit ASCII numeric characters,            MSD transmitted first, LSD last indicating Video Bandwidth in Hz.</p> <p>The possible values for the Video Bandwidth parameters are:</p> <p>00.1.....0.1 Hz            00.2.....0.2 Hz            00.5.....0.5 Hz            01.0.....1.0 Hz            02.0.....2.0 Hz            05.0.....5.0 Hz            10.0.....10.0 Hz</p>

## FIRMWARE TITLE AND VERSION = VER

The QUERY command requires no parameters. It returns an twenty-two character ASCII response containing the firmware control drawing number and the firmware revision numbers..

Command	Parameters
Remote Command Sequence:	?VER
Unit Response:	?VERDddddVn.nnn ?VERccDddddVnn.nn
	<p>cc = 00-01 are other firmware versions contained in build            Position "00" is for the DSP firmware revision            Position "01" is for the AVR firmware revision</p> <p>D: document number identifier            ddddd: Six-digit firmware document control drawing number            160041 is total firmware build document number            191431 is the DSP firmware document number            191432 is the AVR firmware document number</p> <p>V: version number identifier            n.nnn: version of build firmware            nn.nn = version of AVR or DSP firmware</p>

## SYSTEM VOLTAGES = VLT

There is no SET command.

The QUERY command requires no parameters.

Command	Parameters
Remote Command Sequence:	?VLT
Unit Response:	?VLTAAa.aaBb.bbCc.ccDd.ddEe.eeFsf. ff
	<p>VLT: System Voltage indicator</p> <p>A: 15 Volt supply indicator            aa.aa: +15.00 Volt Supply Rail voltage</p> <p>B: 5 Volt supply indicator            b.bb: +5.00 Volt Supply Rail voltage</p> <p>C: 3.3 Volt supply indicator            c.cc: +3.30 Volt Supply Rail voltage</p> <p>D: 1.6 Volt supply indicator            d.dd: +1.60 Volt Supply Rail voltage</p> <p>E: 1.8 Volt supply indicator            e.ee: +1.80 Volt Supply Rail voltage</p> <p>F: -15 Volt supply indicator            sff.ff: -15.00 Volt Supply Rail voltage</p>

## EXTERNAL REFERENCE = XRF

There is no SET command.

The QUERY command requires no parameters.

Command	Parameters
Remote Command Sequence:	?XRF
Unit Response:	?XRFi
	i: One-digit ASCII numeric character indicating the clock source of the Beacon Receiver '0' = Local reference '1' = External reference

## EXAMPLES

The following are typical commands and responses showing the ASCII printable characters. The address is 41H (ASCII code 'A') for these examples.

Return the number of entries stored in the Event log.

Command	Parameters
Remote Command Sequence:	{A?LOG00}>
Unit Response:	{A?LOG12}A



## ETHERNET INTERFACE

The MITEQ Beacon Receiver is equipped with an Ethernet Interface feature permitting control and monitoring via a 10 or 100 Mbps Ethernet connection. Available interface protocols are HTTP (web access), SNMP (Simple Network Management Protocol), and Telnet. In addition, a capability to remotely upgrade the system firmware is provided.

The use of standard protocols makes it possible to provide (password-protected) access to the Receiver from any location in the world where an Internet connection is available

## CONNECTION

The Receiver must be connected to the facility Local Area Network (LAN) network via an industry-standard 10baseT RJ45 cable. The cable should be a "direct" cable, not a "crossover" cable. The Receiver may also be connected directly to a PC without a LAN, using a "crossover" cable.

Direct Cable Wiring				Crossover Cable Wiring		
End 1	Color	End 2	Signal	End 1	Color	End 2
1	white/orange	1	TX+	1	white/orange	3
2	orange	2	Tx-	2	orange	6
3	white/green	3	Rx+	3	white/green	1
4	blue	4	unused	4	blue	4
5	white/blue	5	unused	5	white/blue	5
6	green	6	Rx-	6	green	2
7	white/brown	7	unused	7	white/brown	7
8	brown	8	unused	8	brown	8

**Table 5-1. Ethernet Cable Wiring**

## SET UP

Setup of the Ethernet Interface should be attempted only after the Receiver is fully installed and functioning, in accordance with the Operation and Maintenance Manual. Once the Receiver is operating, then the Ethernet Interface may be configured.

## CONFIGURING INTERNET PROTOCOL (IP) OPERATING PARAMETERS

An Internet Protocol (IP) address and associated parameters must be configured in the unit so the controlling device can address it. Normally, the individual or organization managing the facility's LAN assigns this address.

The Ethernet address and associated parameters may be configured using the front panel keypad or the serial interface, or via a web browser. The default factory settings are recorded on the Final Test Data Sheet.

If the network cannot dynamically assign an IP address (or the unit is to be connected directly to a PC) then the Internet Protocol (IP) address and associated parameters must be configured manually.

For the direct connection to a PC any address can be chosen but the PC must also be configured correctly. In this configuration, the PC must be configured with a Static IP address. The procedure for configuring this address varies between operating system types and versions. Consult the operating manual or help files available with the computer to be used to determine the proper procedure for configuring the PC's IP address.

Three parameters will be required on the Beacon Receiver:

Parameters	Factory Setting
IP Address	192.168.1.1
Subnet Mask	255.255.255.0
Gateway	192.168.1.1

The computer must be configured with the same Subnet Mask as the Receiver, but a different IP address, to connect properly. For connecting with the Receiver Static IP address in the example above, the following settings are recommended for the PC:

Parameters	Factory Setting
IP Address	(corresponding PC setting 192.168.1.2)
Subnet Mask	(corresponding PC setting 255.255.255.0)
Gateway	(corresponding PC setting 192.168.1.1)

The Ethernet address may be configured either via the serial interface or via a MITEQ supplied Windows™ application (page 59).

Changing the IP settings will disrupt any open sessions (HTML, SNMP or Telnet), cause the unit to reset and the operator will be required to reconnect to the unit at the new settings.

## CONFIGURING VIA SERIAL INTERFACE

The command listed below may be used to enter the IP parameters. The command must be transmitted with the standard MITEQ protocol, as described in Remote Interface section of this document. Note that the factory default settings of the serial port are as follows:

Baud: 9600  
 Parity: Odd  
 Address: 64 (40H or ASCII: @)

Command	Parameters
Remote Command Sequence:	\$EADliiiiiiiiiiGgggggggggggSsssssssssss
Unit Response:	\$EAD
	<p>EAD: Ethernet Address indicator. If the indicator is capitalized in the remote response, then the IP address that was set is a Static IP address. If the indicator is in lower case letters then the IP address is a Dynamic IP address and was obtained using DHCP (Dynamic Host Configuration Protocol) server to assign the IP address.</p> <p>I: Ethernet IP Address parameter indicator            iiiiiiiiii: Twelve-digit ASCII numeric characters,            * = no change to stored value in position</p> <p>G: Ethernet gateway parameter indicator            gggggggggggg: Twelve-digit ASCII numeric characters,            * = no change to stored value in position</p> <p>S: Ethernet Subnet mask parameter indicator            ssssssssssss: Twelve-digit ASCII numeric characters,            * = no change to stored value in position</p>

The values may be verified using the corresponding query command (?EAD)

## CONFIGURING VIA IPSETUP APPLICATION

IPSETUP.exe is a Windows™ application, which can be obtained from MITEQ or at the following URL:  
[http://www.netburner.com/support/public\\_downloads.html](http://www.netburner.com/support/public_downloads.html).

Through an Ethernet connection to the Receiver, the IP Setup application can re-assign the IP address of the Beacon Receiver. For an example, if the Receiver is connected to a PC through a crossover cable (and the IP address of the PC is 192.168.001.002), the address of the Receiver can be set to 192.168.001.001.

- Make sure that the Beacon Receiver is in the Remote control mode
- Open the application IPSETUP.exe
- The application should open and show a listing of the IP addresses of what has been found by the computer. If the Receiver is unable to dynamically assign an IP address, it will show up as a unit at IP address 0.0.0.0.
- Highlight this address from "Select a Unit".
- From "NDK Settings" at the "IP" line begin to enter the IP address of the NSU.
- Press "Set→", the Receiver will reset and a few seconds later the new IP address should show up in the "Select a Unit" list at IP address 192.168.1.1.
- If the list on the application doesn't change press "Search Again".

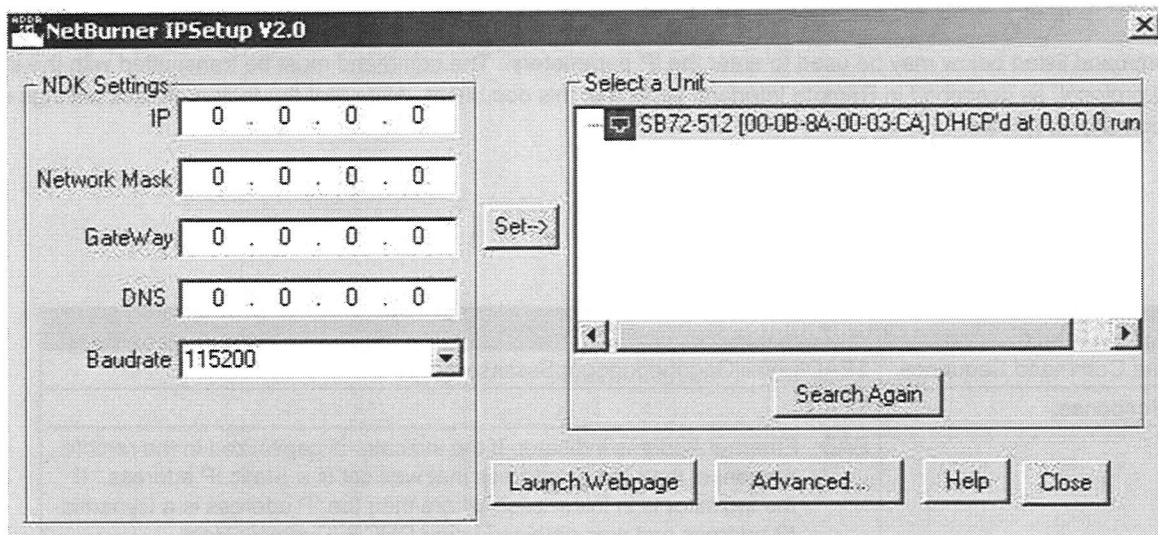

Figure 5-21. IPSETUP Application

## VERIFYING PROPER CONNECTION AND CONFIGURATION

The connection and configuration may be verified from a PC attached to the LAN using the network “ping” command. From a command prompt, enter

**“ping <assigned IP address>”**

The response will indicate whether a connection was established.

## ACCESSING THE SYSTEM THROUGH THE ETHERNET CONNECTION

### ACCESS VIA THE WEB INTERFACE

All system setting may be may be queried or modified via the Web Interface. The web page designs have been optimized for the use with the Microsoft Internet Explorer (MSIE) Version 5.0 web browser, or higher. Use of Cookies must be enabled (see the TOOLS|INTERNET OPTIONS|PRIVACY setting).

Web access may function properly, or with somewhat degraded performance, using other browsers of the same vintage. Browsers of earlier vintage are not recommended.

To connect to the unit, launch the web browser on any PC connected to the same LAN, and enter the address

**http://<assigned IP address>**

A sign-on page requesting the password should be displayed. The default password is “11111”.

The operator may navigate between the available pages by clicking on the button images located about 1/3 of the way down from the top of the screen.



Model: (model not set)

**Please Log In**

---

Enter Password:



**Figure 5-22. Login Screen**

Once logged in the home page will appear. At the top of each page the MITEQ logo along with the model number of the unit is displayed.



Model: BR-L

### Beacon Receiver

Auto Gain CTRL   Remote   Internal Reference   Summary Alarm   Receiver Lock

Home   Memory   Comms   Time   Misc   Event Log   Log Out

Home

UNLOCKED

LO Alarm	Input High	Input Low	Pwr Uncalibrated	RF Over Range	Test Alarm
15 V Pwr Supply	5 V Pwr Supply	3.3V Pwr Supply	1.8V Pwr Supply	1.6 V Pwr Supply	-15 V Pwr Supply

Center Frequency: 1850000000 Hz

Maximum Voltage: +10.0 V

Tracking Range: ±700 KHz

Nominal Voltage: +10.0 V

Aquisition Range: ±10 KHz

Minimum Voltage: +0.0 V

Tuner Bandwidth: 7.5 KHz

Slope: +0.5 dB/V

Video Bandwidth: 5.0 Hz

Nominal Pwr Level: -110.0 dBm

Hold Time: 300 secs

RF Gain: +10.0 dBm

Gain Control: Automatic

IF Gain: -10.0 dBm

Measurement Mode: Peak

Set Ref level to current Measured Power level:

Live Spectrum Plot

History Plot

Set Test Alarm:

Submit

Figure 5-23. Home Screen

Alarm Status, Unit title and active setup title appear on all of the remaining pages.

The operator may navigate between the available pages by clicking the buttons toward the top of the screen.

To set an operating parameter, make the appropriate changes, change the (screen locked) pull-down to UNLOCKED, and press the Submit or other applicable button.

From the home page the Receivers RF settings can be changed.

Live Spectrum Plot: Displays graphical representation of input spectrum to Beacon Receiver.



Model: BR-L

Beacon Receiver

Auto Gain CTRL	Local	External Reference	Summary Alarm	Receiver Lock		
Home	Memory	Comms	Time	Misc	Event Log	Log Out

Live Spectral Plot

(screen locked) ▾

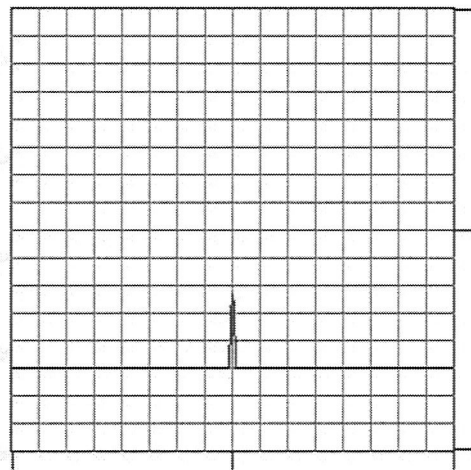

Figure 5-24. Live Spectrum Plot Screen

The operator may navigate between the available pages by clicking the buttons toward the top of the screen.

There are no settable parameters on this screen.



Model: BR-L

Beacon Receiver

Auto Gain CTRL   Remote   Internal Reference   Summary Alarm   Receiver Lock

Home   Memory   Comms   Time   Misc   Event Log   Log Out

Memory 01

UNLOCKED

Name: DEFAULT 01

Center Frequency: 1850000000 Hz      Maximum Voltage: +10.0 V

Tracking Range: ±100 KHz      Nominal Voltage: +10.0 V

Aquisition Range: 0 KHz      Minimum Voltage: +0.0 V

Tuner Bandwidth: 7.5 KHz      Slope: +0.5 dB/V

Video Bandwidth: 5.0 Hz      Nominal Pwr Level: -110.0 dBm

Hold Time: 120 secs      RF Gain: +10.0 dBm

Gain Control: Automatic      IF Gain: -10.0 dBm

Measurement Mode: Peak

Set From Memory   Save And Set   Save Memory

- 01
- 02
- 03
- 04
- 05
- 06
- 07
- 08
- 09
- 10
- 11
- 12
- 13
- 14
- 15
- 16



Figure 5-25. Memory Screen

Memory Page	
Function Name	Description
Memory Number	Select or view the memory location number
Setup Name	Select or view the memory setup name
Frequency	Select or view the memory RF frequency
Attenuation	Select or view the memory attenuation setting
View Memory	Recall the specified memory number and show its values without changing the Receiver settings
Set from Memory	Recall the specified memory number and load its values to the Receiver
Save Memory	Save the specified settings at the specified memory number without changing the Receiver settings
Save and Set	Save the specified settings at the specified memory number without changing the Receiver settings





Model BR-L

**Beacon Receiver**

Auto Gain Ctrl   
  Remote   
  External Reference   
  Summary Alarm   
  Receiver Lock

UNLOCKED ▾

**IP Settings**      **SNMP Settings**

IP Address	192.168.1.249	System Name	noname
Subnet Mask	192.168.1.1	System Contact	nocontact
Gateway	255.255.255.0	System Location	nolocation
Warning: Changing IP settings will disconnect session		Read Community	public
		Write Community	private
		Trap Destination	192.168.1.99
<input type="button" value="Update IP"/>		<input type="button" value="Update SNMP"/>	

**RS232 / RS422 / RS485**

Parity	Odd ▾	Bus	RS485 ▾
Address	64 ▾	Baud Rate	19200 ▾
<input type="button" value="Submit"/>			

**Figure 5-26. Communications Screen**

The Communications provides access to the communication settings of the unit. Changing the IP settings will disrupt the session and the operator will be required to reconnect to the unit at the new settings. These can be set from the front panel. SNMP parameters can also be defined from this page. The table below describes the fields on the Communications page.

Communications Page	
Function Name	Description
IP Address	View or set the system IP address (changing this value will reset the system)
IP Subnet Mask	View or set the system IP Subnet Mask (changing this value will reset the system)
IP Gateway	View or set the system IP Gateway (changing this value will reset the system)
System Contact	View or set the SNMP System Contact parameter
System Name	View or set the SNMP System Name parameter
System Location	View or set the SNMP System Location parameter
Read Community	View or set the SNMP Read Community parameter (enter a long arbitrary string to make SNMP inaccessible)
Write Community	View or set the SNMP System Contact parameter (enter a long arbitrary string to make SNMP inaccessible)
Parity	View or set the RS485/422/232 communications bus Parity
Address	View or set the Beacon Receiver communications bus Address
Bus	View or set the Beacon Receiver communications bus Type
Baud Rate	View or set the RS485/422/232 communications bus Baud Rate

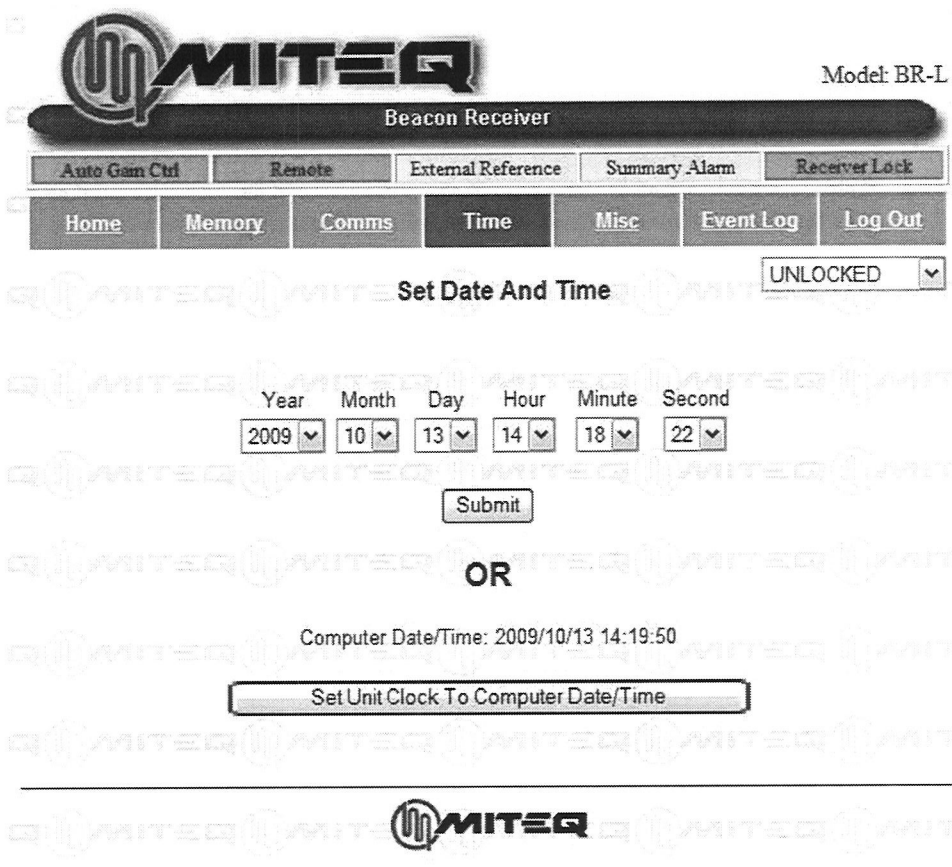

**Figure 5-27. Time and Date Screen**

The unit is equipped with a real time clock which can be adjusted from the time page. Simply use the pull-downs to adjust the display for the desired settings pull down the unlock tab and submit the changes.

Time Page	
Function Name	Description
Set Clock	View or set the system real-time clock
Set Clock to Computer Date/Time	Set the system real-time clock to M&C Computer time

Model:  
BR-L

**Beacon Receiver**

Auto Gain Ctrl   Remote   External Reference   Summary Alarm   Receiver Lock

Home   Memory   Comms   Time   **Misc**   Event Log   Log Out

UNLOCKED ▾

### Misc Settings

Enable Telnet	<input checked="" type="checkbox"/>
Enable Re-flash	<input checked="" type="checkbox"/>
Enable Traps	<input type="checkbox"/>
Send Test Trap	<input type="checkbox"/>
Screen Unlock	<input checked="" type="checkbox"/>
Alarm Refresh Rate	05 (5-99 secs)
Web Timeout *	00 (0-99 minutes)
Trap Repeat Rate *	10 (0-99 minutes)
Version	D160041V2.037

Old Password	<input type="text"/>
New Password	<input type="text"/> (5 digits)
Confirm	<input type="text"/>

(right-click to download SNMP MIB)

\* - (enter 0 for never)

**Figure 5-28. Miscellaneous Settings Page**

The following table describes the fields on the Miscellaneous Page.

Miscellaneous Page	
Function Name	Description
Enable Telnet	Permit or prevent Telnet access
Enable Re-flash	Permit or prevent firmware update
Enable Traps	Permit or prevent Traps for being sent
Sent Test Trap	Send single SNMP Test Trap
Screen Unlock	Unlock Web screens to send data to unit
Alarm Re-fresh rate	View or set how frequently the alarm/fault indications will be refreshed on the Logs page; range is from 0-99 secs
Web Timeout	View or set the time before a web user is logged off due to inactivity
Trap Repeat rate	View or set the frequency with which SNMP traps are resent. A value of 0 will cause traps to be sent only when an alarm initially occurs
Enable Firmware Upgrade	Permit or prevent remote upgrade of the converter Ethernet firmware
Enable Test Alarm	Force a false alarm for test purposes
Old Password New Password New Password	Update the system password (1-5 digits). All three values must be entered. If the old password does not match the existing password, or the two new password entries are different, the update will not occur.



Model BR-L

**Beacon Receiver**

Auto Gain CTRL   Remote   External Reference   Summary Alarm   Receiver Lock

Home   Memory   Comms   Time   Misc   Event Log   Log Out

**Event Log**

UNLOCKED ▾

Clear Event Log

LOG ENTRY	DATE	EVENT DESCRIPTION
64	1923/03/11 09:27:26	RF Calibration Error
63	1923/03/11 09:27:26	Local oscillator lock fault lost
62	1923/03/11 09:27:25	Receiver lock lost
61	1923/03/11 09:27:23	Beacon Receiver Startup
60	1923/03/11 09:17:44	RF Calibration Error
59	1923/03/11 09:17:44	Local oscillator lock fault lost
58	1923/03/11 09:17:44	Receiver lock lost
57	1923/03/11 09:17:41	Beacon Receiver Startup
56	1923/03/11 07:07:08	RF Calibration Error
55	1923/03/11 07:07:08	Input Signal Level high warning

**Figure 5-29. Event Log Page**

The log page allows the user to review the events stored in the event log. The page captures a “snapshot” of the event log. The event log can also be cleared by unlocking the screen and pressing the clear log button.

Event Log Page	
Function Name	Description
Alarm Indicators	View the state of the discrete system alarms
Log Listings	View a listing of all system log entries
Clear Logs	Clear the event log



Model: (model not set)

## Session is Closed

---

**This may be due to:**

Incorrect password entered  
Session timeout  
Cookies are disabled on your web browser  
A Telnet session is in progress  
You configured an IP parameter  
You logged out deliberately

[To log in, click here](#)

---



**Figure 5-30. Logout Page**

Pressing the Logout button will end the session and the following page will appear on the browser.

### ACCESS VIA SNMP

The Beacon Receiver may be accessed and monitored via the Simple Network Management Protocol (SNMP). SNMP is designed for control of network elements from a central management point.

The SNMP Management Information Base (MIB) file for the system can be downloaded from a link in the web interface on the 'MISC Settings' page. The link is just under the change password button and is labeled 'right click to download SNMP MIB file'. The MIB file defines the specifics of the network interface to the receiver. This file is read by the chosen SNMP management tool to provide an "understanding" of the interface. The MIB file is in a format that can be ready with any text editor. DO NOT modify this file. SNMP operating parameters may be set on the COMMS web page.

## ACCESS VIA TELNET

The Beacon Receiver may be accessed via Telnet. There is no special protocol on the Telnet channel; the unit will expect the same commands, and offer the same replies, as via the serial port.

Telnet access must first be enabled on the COMMS web page. If not being used, it is recommended that it be left disabled for security reasons.

When a Telnet connection is established, the Receiver will request the password (five ASCII characters), which can be sent in the standard MITEQ wrapper ('<address byte (ignored)><password>'}<checksum byte>). As an alternative the address and checksum can be replaced by the '{' and '}' characters respectively. Thus the same message to the open Telnet port could look like this: {{<password>}}

The connection will be refused if a user is already logged in via the web interface.

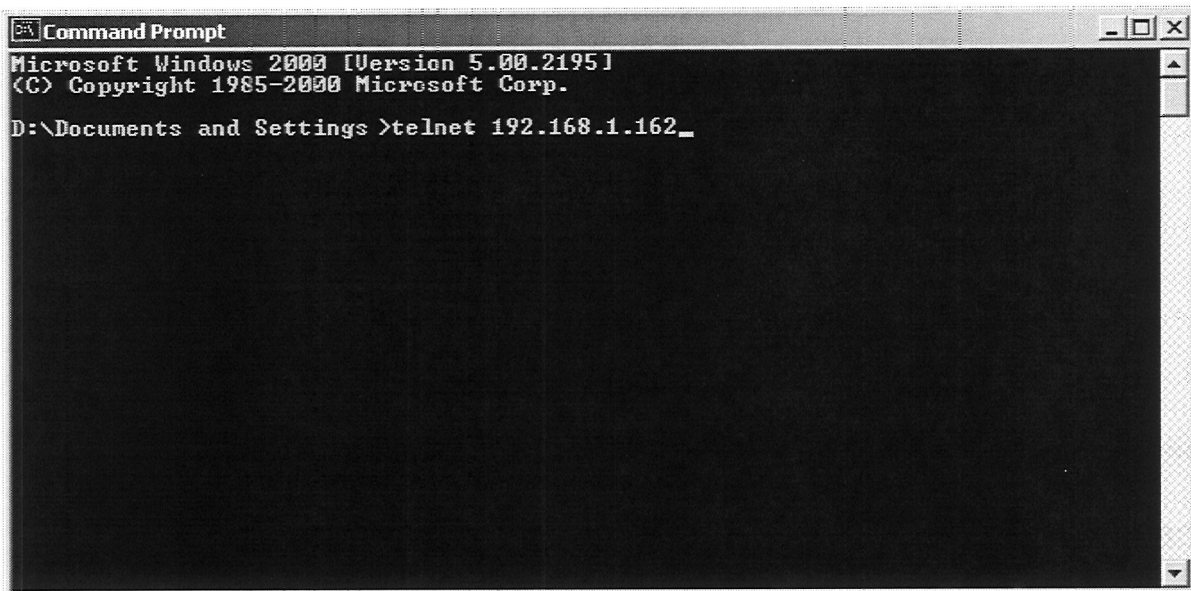

Figure 5-31. Opening Telnet Port

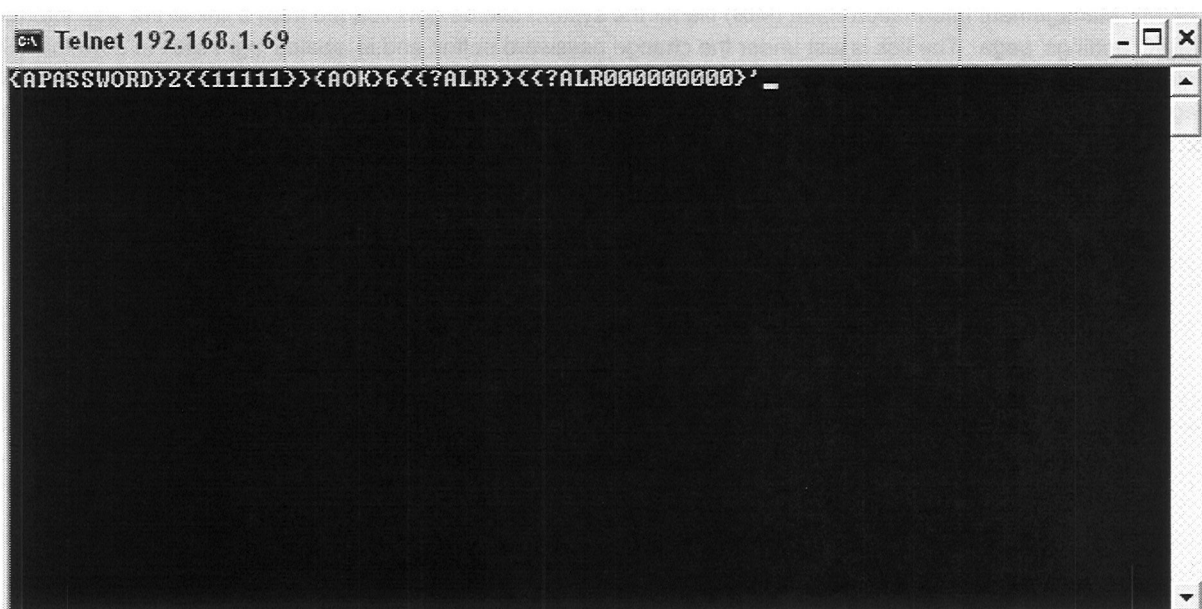

Figure 5-32. Telnet Communications

Once the connection is established, standard serial commands may be sent and responses will be received. Logout is automatic when the Telnet connection is broken. To re-establish the connection, the password will have to be sent again.

## FIRMWARE UPGRADE

Should it become necessary to upgrade the firmware, the updated firmware file and the update utilities will be provided by MITEQ.

- Make sure that the Receiver is in the Remote control mode
- Access the web page for the Receiver. Note the IP Address and password of the NSU unit.
- Go to the Misc Settings page and make sure that Enable Reflash is checked.
- Install the update utility provided by MITEQ: AutoUpdate.exe and the xxx\_APP.s19 firmware upgrade files on your computer. Make a note of where you save the files.
- Start AutoUpdate.exe.
- To set the IP address to flash: Click "Find...", it will show a list of Ethernet-based units that the application detected. Highlight the address you wish to reflash and click "OK".
- Click "Browse..." and select the xxx\_APP.s19 file for updating to the Receiver.
- Check the box that reads "Reboot When Complete."
- Start the update process. Click "Update"
- If the Receiver password has not been disabled, a "Password needed" box will appear. For the user name type Receiver. Enter the password that you use to login to the web page.
- A progress screen will appear. When complete a message box that reports if the process completed successfully or not. Successful programming takes approximately 10 seconds, unsuccessful programming can take as long as 2 minutes to time out.
- After a firmware upgrade it is recommended to return the unit to its factory default settings. That is done by power cycling the unit with the "down" arrow held down. When the unit displays "erasing memory" the key can be released. All user settings will need to be restored at that point.

After the upgrade, it will be necessary to log in again. The new firmware version will be visible on the login page.

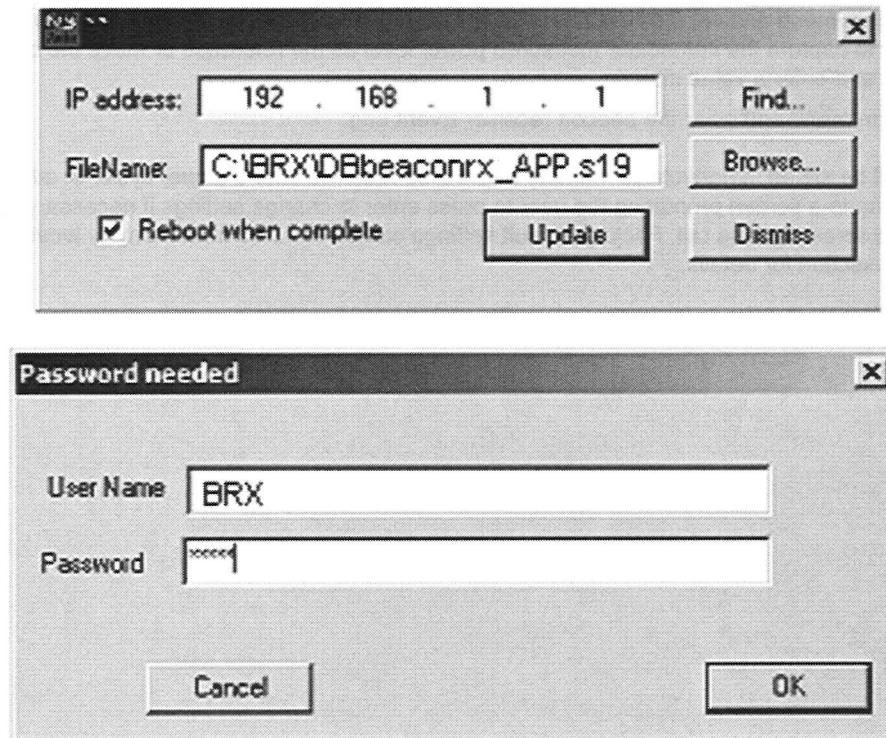

Figure 5-33. AutoUpdate Application Screens

## SET UP GUIDE

This section describes how to configure the beacon receiver from the front panel.

1. If the application requires connecting external equipment to the beacon receiver analog voltage output page to the output menu and set the output voltage limits. The defaults are min -10.0 V, ref 0 V, max +10.0 V and slope 1.0 dB/V.
2. Page to the remote menu and set the remote communications parameters if required. Set the remote/local parameter to local. Verify the remote led on the front panel is off. The defaults are remote, RS422, address 64, 19.2 KB, odd parity.
3. Connect the analog output voltage and RF source. Connect the 10 MHz frequency reference and remote interfaces if available. If a 10 MHz reference is connected verify the EXT REF led on the front panel is lit.
4. Page to the utility menu and set the beacon receiver date and time and adjust contrast if required.
5. Page to the main menu and set the beacon receiver center frequency.
6. Page to the acquisition menu and set the beacon receiver tuner bandwidth, acquisition and tracking ranges if required. Select a lower tuner bandwidth for a low C/N carrier or wider tuner bandwidth for a modulated carrier. Select acquisition and tracking ranges depending on the expected carrier drift. The defaults are acquisition range +/- 500 kHz, tracking range +/- 500 kHz and tuner bandwidth 150 kHz.
7. Page to the video bandwidth menu and set the measurement mode. Select total power for a measurement that will not be effected by modulation within the tuner bandwidth. The default is total power. Set holdtime. Set video bandwidth
8. Page to the RF gain menu and set the beacon receiver RF gain. Move the cursor to the set parameter and press enter or move the cursor to the gain parameter enter a gain value directly. The RF gain should be set so that the indicator is near the middle of the scale. If "RF LEVEL LOW" is indicated a higher level input may be required.
9. Page to the IF gain menu and set the beacon receiver IF gain. Move the cursor to the mode parameter and select auto or manual. In auto mode the beacon receiver will select the optimum IF gain setting. In manual mode an IF gain value must be entered at the gain parameter.
10. The beacon receiver should lock and light the lock led. Page to the main menu to observe the measured power level, output voltage and frequency offset.
11. Page to the IF gain menu and set the beacon receiver Reference Level. Move the cursor to the input level parameter and press enter to capture the immediate measured power level as the reference or move the cursor to the reference level parameter and enter a value directly.
12. Page to the alarm menu and clear the beacon receiver Event Log.

All of the settings will be saved in nonvolatile memory and will be restored after a power cycle. In addition the Beacon Receiver will power up to a screen prompting the user to press enter to change settings if necessary. Press menu to continue or allow the screen to time out. Factory default settings can be restored from memory location 16. See the "Memory Functions" section for details.



## **SECTION 6: BEACON RECEIVER COMPONENT PRINCIPLES OF OPERATION**

### **INTRODUCTION**

The Beacon Receiver has 2 main components: the RF module and the DSP board. The following paragraphs provide information on their principles of operation.

### **RF MODULE FUNCTIONAL DESCRIPTION**

The RF module provides the input to the beacon receiver (BR). The L-band signal is connected to the RF module of the beacon receiver. The signal is block converted to 10.7 MHz center frequency using a fine resolution DDS synthesizer. After the conversion the signal is passed through a fixed Band Pass Filter (BPF) and then through a switched bank of band pass filters. The customer controls the switched bank, and that defines the "tuner bandwidth". The tuner Bandwidth is defined by 3 fixed filters selectable from the front panel (or remotely). The three filter bandwidths are 7.5 kHz, 150 kHz and 340 kHz. The purpose of these filters is to allow tunability as a function of signal to noise ratio. For example, if the signal to noise ratio is poor (low beacon level) the receiver should be set to the narrowest tuner bandwidth i.e. 7.5 kHz. The impact of setting the receiver to the narrowest filter is slow sweep time or slow locking time.

### **DSP BOARD FUNCTIONAL DESCRIPTION**

The DSP (digital signal processing) board is the heart of the BR. Its function is to process the 10.7 MHz converted L-Band beacon signal and then report in various forms on the beacon power and frequency location.

The DSP board controls and monitors the output level of the RF module is very closely. The processor detects the signal levels at the input and the output of the RF module. Based on these two powers the processor can vary the gain of the RF module and bring it to a nominal level where the power coming out of the module does not compress the DSP board. Another function of the DSP board is the frequency tuning. The DSP board scans the RF band based on the customer input. The BR has 7 discreet search ranges: +/-700 kHz, +/-500 kHz, +/-200 kHz, +/-100 kHz, +/-50 kHz, +/-20 kHz, +/-10 kHz. After the customer has set the center frequency (where he believes the beacon signal is present) and the scan band width the DSP board will vary the frequency of the synthesizer until it locks to the highest peak in the search band. Once the gain of the RF module is set and the BR has locked on the beacon signal, the DSP board will report the frequency and power of the beacon signal.

There are two outputs from the BR. The first is a DC voltage that varies relative to the beacon signal power. This voltage is used to feed the antenna control system. The second output is from the front panel display, the remote HTML page or serial port. These pages display the settings of the BR and also information about the locked signal, frequency and power.

REVISIONS		DATE	APPROVED
ZONE	LTR	DESCRIPTION	
B		REVISED PER ECN 12569	09/17/09 <i>J. Poggiano</i>

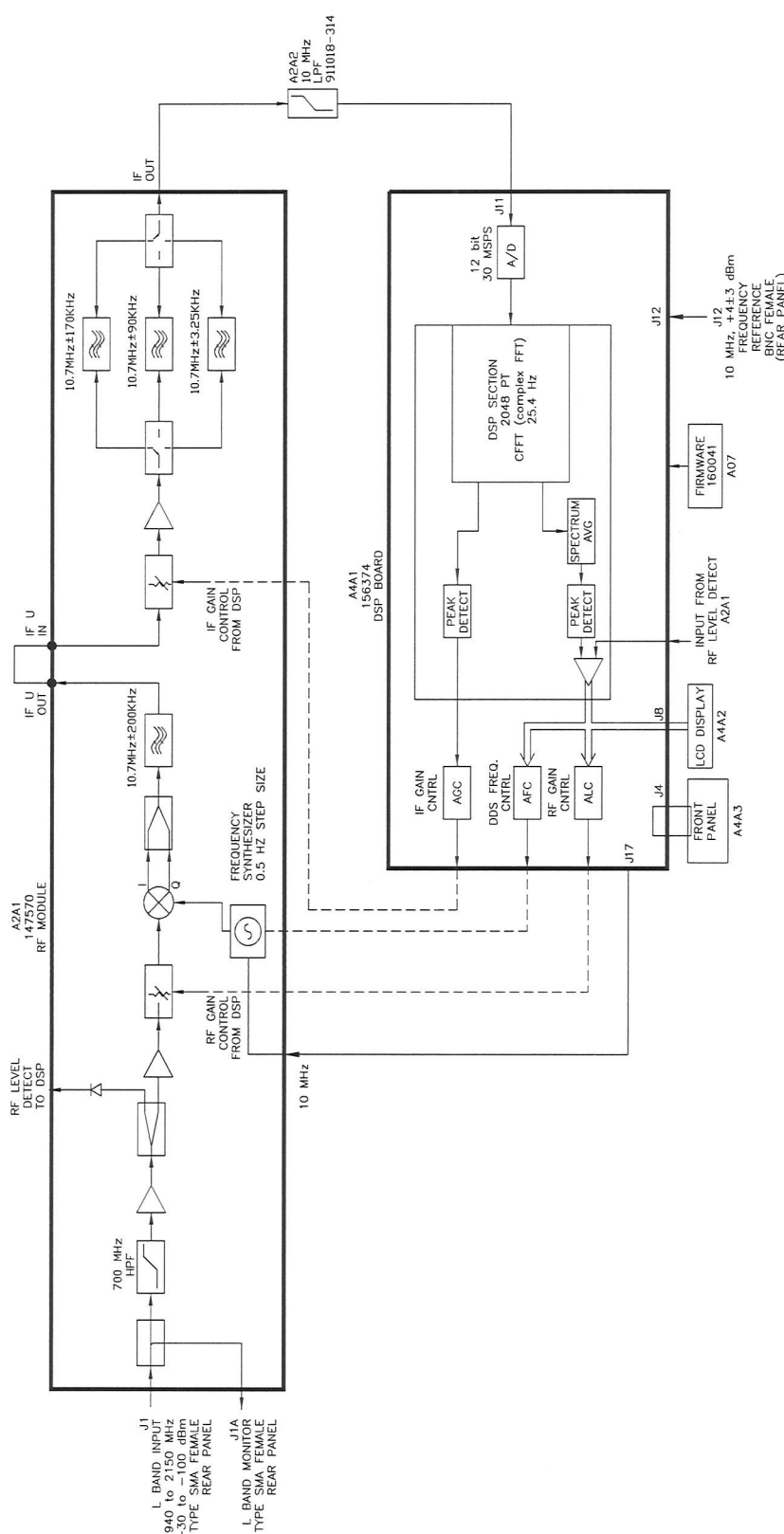

QTY	REQD	NOMENCLATURE OR DESCRIPTION	SYM/NOTES	PART NO.	CODE IDENT	ITEM NO.
1	1	UNLESS OTHERWISE SPECIFIED DIMENSIONS ARE IN INCHES TOLERANCES ON ANGLES DECIMALS .XX±.01 .XXX±.005 ±0°30'				
		MATERIAL				
		FINISH				
		NEXT ASSY				
		USED ON				
		APPLICATION				
		HEAT TREAT				

PARTS LIST		SYN/NOTES		PART NO.		CODE IDENT		ITEM NO.	
<p>182945</p>									
<p>10 MHz FREQUENCY REFERENCE (REAR PANEL)</p>									
<p>10 MHz, ±4±.3 dBm</p>									
<p>J12</p>									
<p>FIRMWARE 160041 A07</p>									
<p>J17</p>									
<p>J18</p>									
<p>J19</p>									
<p>J20</p>									
<p>J21</p>									
<p>J22</p>									
<p>J23</p>									
<p>J24</p>									
<p>J25</p>									
<p>J26</p>									
<p>J27</p>									
<p>J28</p>									
<p>J29</p>									
<p>J30</p>									
<p>J31</p>									
<p>J32</p>									
<p>J33</p>									
<p>J34</p>									
<p>J35</p>									
<p>J36</p>									
<p>J37</p>									
<p>J38</p>									
<p>J39</p>									
<p>J40</p>									
<p>J41</p>									
<p>J42</p>									
<p>J43</p>									
<p>J44</p>									
<p>J45</p>									
<p>J46</p>									
<p>J47</p>									
<p>J48</p>									
<p>J49</p>									
<p>J50</p>									
<p>J51</p>									
<p>J52</p>									
<p>J53</p>									
<p>J54</p>									
<p>J55</p>									
<p>J56</p>									
<p>J57</p>									
<p>J58</p>									
<p>J59</p>									
<p>J60</p>									
<p>J61</p>									
<p>J62</p>									
<p>J63</p>									
<p>J64</p>									
<p>J65</p>									
<p>J66</p>									
<p>J67</p>									
<p>J68</p>									
<p>J69</p>									
<p>J70</p>									
<p>J71</p>									
<p>J72</p>									
<p>J73</p>									
<p>J74</p>									
<p>J75</p>									
<p>J76</p>									
<p>J77</p>									
<p>J78</p>									
<p>J79</p>									
<p>J80</p>									
<p>J81</p>									
<p>J82</p>									
<p>J83</p>									
<p>J84</p>									
<p>J85</p>									
<p>J86</p>									
<p>J87</p>									
<p>J88</p>									
<p>J89</p>									
<p>J90</p>									
<p>J91</p>									
<p>J92</p>									
<p>J93</p>									
<p>J94</p>									
<p>J95</p>									
<p>J96</p>									
<p>J97</p>									
<p>J98</p>									
<p>J99</p>									
<p>J100</p>									

PARTS LIST		SYN/NOTES		PART NO.		CODE IDENT		ITEM NO.	
<p>182945</p>									
<p>10 MHz FREQUENCY REFERENCE (REAR PANEL)</p>									
<p>10 MHz, ±4±.3 dBm</p>									
<p>J12</p>									
<p>FIRMWARE 160041 A07</p>									
<p>J17</p>									
<p>J18</p>									
<p>J19</p>									
<p>J20</p>									
<p>J21</p>									
<p>J22</p>									
<p>J23</p>									
<p>J24</p>									
<p>J25</p>									
<p>J26</p>									
<p>J27</p>									
<p>J28</p>									
<p>J29</p>									
<p>J30</p>									
<p>J31</p>									
<p>J32</p>									
<p>J33</p>									
<p>J34</p>									
<p>J35</p>									
<p>J36</p>									
<p>J37</p>									
<p>J38</p>									
<p>J39</p>									
<p>J40</p>									
<p>J41</p>									
<p>J42</p>									
<p>J43</p>									
<p>J44</p>									
<p>J45</p>									
<p>J46</p>									
<p>J47</p>									
<p>J48</p>									
<p>J49</p>									
<p>J50</p>									
<p>J51</p>									
<p>J52</p>									
<p>J53</p>									
<p>J54</p>									
<p>J55</p>									
<p>J56</p>									
<p>J57</p>									
<p>J58</p>									
<p>J59</p>									
<p>J60</p>									
<p>J61</p>									
<p>J62</p>									
<p>J63</p>									
<p>J64</p>									
<p>J65</p>									
<p>J66</p>									
<p>J67</p>									
<p>J68</p>									
<p>J69</p>									
<p>J70</p>									
<p>J71</p>									
<p>J72</p>									
<p>J73</p>									
<p>J74</p>									
<p>J75</p>									
<p>J76</p>									
<p>J77</p>									
<p>J78</p>									
<p>J79</p>									
<p>J80</p>									
<p>J81</p>									
<p>J82</p>									
<p>J83</p>									
<p>J84</p>									
<p>J85</p>									
<p>J86</p>									
<p>J87</p>									
<p>J88</p>									
<p>J89</p>									
<p>J90</p>									
<p>J91</p>									
<p>J92</p>									
<p>J93</p>									
<p>J94</p>									
<p>J95</p>									
<p>J96</p>									
<p>J97</p>									
<p>J98</p>									
<p>J99</p>									
<p>J100</p>									

PARTS LIST		SYN/NOTES		PART NO.		CODE IDENT		ITEM NO.	
<p>182945</p>									
<p>10 MHz FREQUENCY REFERENCE (REAR PANEL)</p>									
<p>10 MHz, ±4±.3 dBm</p>									
<p>J12</p>									
<p>FIRMWARE 160041 A07</p>									
<p>J17</p>									
<p>J18</p>									
<p>J19</p>									
<p>J20</p>									
<p>J21</p>									
<p>J22</p>									
<p>J23</p>									
<p>J24</p>									
<p>J25</p>									
<p>J26</p>									
<p>J27</p>									
<p>J28</p>									
<p>J29</p>									
<p>J30</p>									
<p>J31</p>									
<p>J32</p>									
<p>J33</p>									
<p>J34</p>									
<p>J35</p>									
<p>J36</p>									
<p>J37</p>									
<p>J38</p>									
<p>J39</p>									
<p>J40</p>									
<p>J41</p>									
<p>J42</p>									
<p>J43</p>									
<p>J44</p>									
<p>J45</p>									
<p>J46</p>									
<p>J47</p>									
<p>J48</p>									
<p>J49</p>									
<p>J50</p>									
<p>J51</p>									
<p>J52</p>									
<p>J53</p>									
<p>J54</p>									
<p>J55</p>									
<p>J56</p>									
<p>J57</p>									
<p>J58</p>									
<p>J59</p>									
<p>J60</p>									
<p>J61</p>									
<p>J62</p>									
<p>J63</p>									
<p>J64</p>									
<p>J65</p>									
<p>J66</p>									
<p>J67</p>									
<p>J68</p>									
<p>J69</p>									
<p>J70</p>									
<p>J71</p>									
<p>J72</p>									
<p>J73</p>									
<p>J74</p>									
<p>J75</p>									
<p>J76</p>									
<p>J77</p>									
<p>J78</p>									
<p>J79</p>									
<p>J80</p>									
<p>J81</p>									
<p>J82</p>									
<p>J83</p>									
<p>J84</p>									
<p>J85</p>									
<p>J86</p>									
<p>J87</p>									
<p>J88</p>									
<p>J89</p>									
<p>J90</p>									
<p>J91</p>									
<p>J92</p>									
<p>J93</p>									
<p>J94</p>									
<p>J95</p>									
<p>J96</p>									
<p>J97</p>									
<p>J98</p>									
<p>J99</p>									
<p>J100</p>									

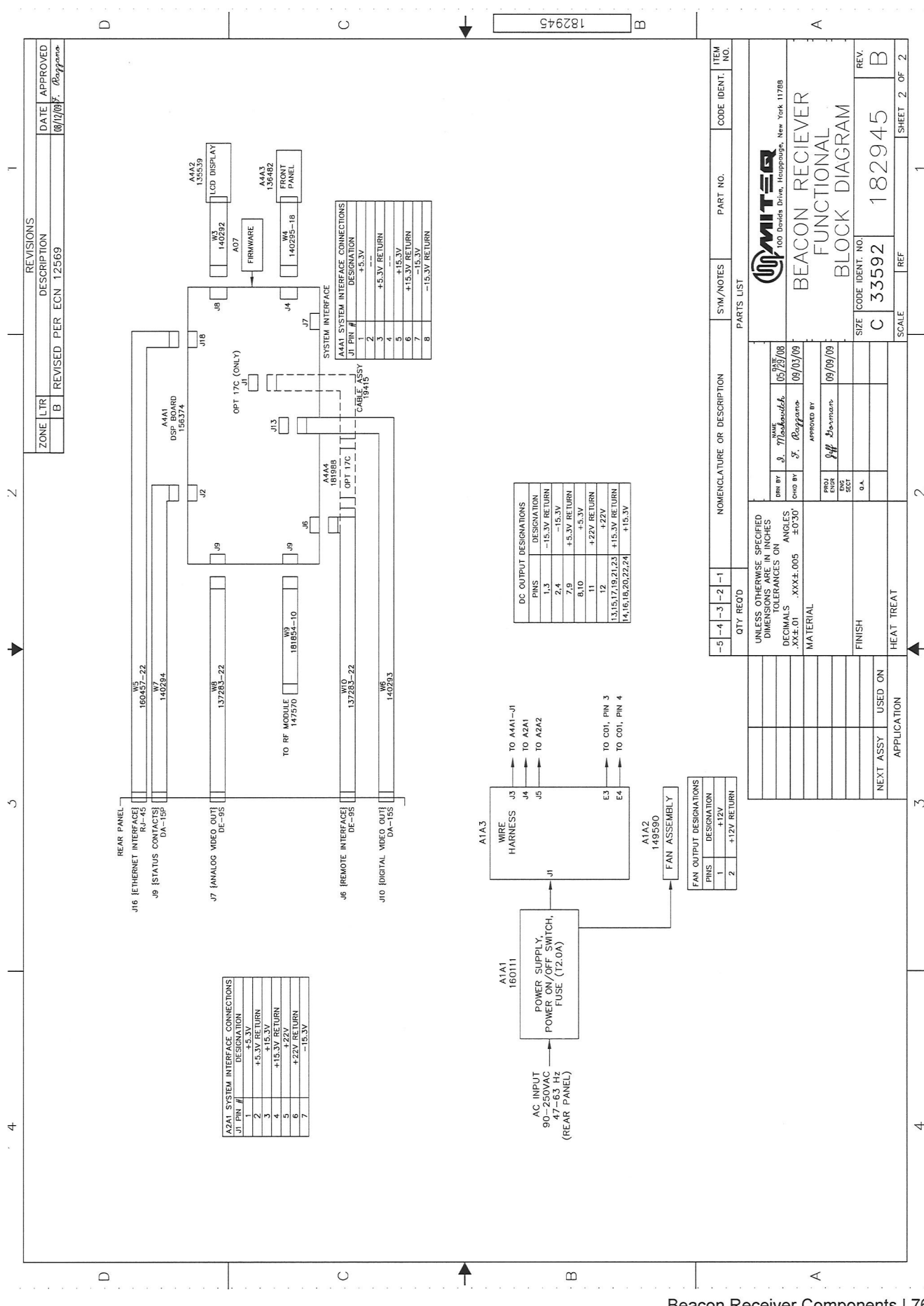

ZONE	LTR	DESCRIPTION	DATE	APPROVED
B		REVISED PER ECN 12569	08/12/09	F. Poggiano

QTY	REQ'D	NOMENCLATURE OR DESCRIPTION	PART NO.	CODE IDENT	ITEM NO.
-5	-4	-3	-2	-1	

UNLESS OTHERWISE SPECIFIED DIMENSIONS ARE IN INCHES	DECIMALS TOLERANCES ON ANGLES	APPROVED BY	DATE
.XXX±0.01	.XXX±.005 ±0°30'	J. Poggiano	05/23/08
		J. Poggiano	09/03/09
		J. Poggiano	09/09/09

FINISH	USED ON	APPLICATION	SCALE	REF	SHEET	OF
HEAT TREAT			1		2	2

SIZE	CODE IDENT. NO.	REV.
C 33592	182945	B

MITED  
100 Doves Drive, Hauppauge, New York 11788

BEACON RECEIVER  
FUNCTIONAL  
BLOCK DIAGRAM

## MAJOR SUBASSEMBLIES FUNCTIONAL DESCRIPTION

### RF MODULE

SPECIFICATIONS	
Input frequency	940-2150 MHz
Output frequency	10.7 MHz $\pm$ 170 kHz, or 10.7 MHz $\pm$ 75 kHz, or 10.7 MHz $\pm$ 3.75 kHz
Input return loss	-15 dB minimum
RF monitor port	20 dBc nominal
RF-path gain	60 dB minimum
RF-path gain adjust	50 dB minimum
IF-path gain	47 dB minimum
IF-path gain adjust	50 dB minimum

### POWER SUPPLY

The Power Supply has an integrated AC line input and illuminated rocker type power on/off switch. The fuse is top mounted flush with the top surface of the converter. Accessible voltage adjustment potentiometers are provided for the +15.3V, +5.3V "A" and +5.3V "B" outputs by removing the converter cover. Over-voltage protection is included for all sections of the power supply.

SPECIFICATIONS	
Part Number	160111
AC input	90 VAC to 265 VAC, 45 Hz to 66 Hz
Input connector type	IEC 320 socket
Fuse value:	1.25A
Fuse type	Time-lag
Fuse size	5 x 20 mm
DC Output Voltage Tolerances - +22V +15V +5V -15V	+22 $\pm$ 2V +15.3 $\pm$ 0.25V +5.3 $\pm$ 0.2V -15.3V $\pm$ 0.25V
DC Output Pins - Pins 1, 3 Pins 2, 4 Pins 7, 9 Pins 8, 10 Pin 11 Pin 12 Pins 13, 15, 17, 19, 21, 23 Pins 14, 16, 18, 20, 22, 24	-15.3V Return -15.3V +5.3V Return +5.3V +22V Return +22V +15.3V Return +15.3V
Fan Output Pins - Pin 1 Pin 2	+12V +12V Return
Power factor (For Reference Only)	0.8 nominal
Power supply efficiency (For Reference Only):	80% nominal

## SECTION 7: MAINTENANCE

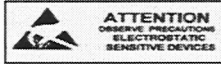

**PROPER GROUNDING PRECAUTIONS  
ARE REQUIRED AT ALL TIMES TO  
PREVENT DAMAGE FROM ESD WHILE  
HANDLING THIS UNIT**

### PREVENTIVE MAINTENANCE

The unit is a completely solid state design. Normal periodic inspection for cleanliness and mechanical integrity should be made in accordance with standard procedures.

Periodic monitoring of the overall performance parameters that are most indicative of equipment performance is required. A log should be maintained that will provide a permanent record of performance and compares it to factory supplied data. By doing so, any long term degradation, erratic or abnormal performance can be detected. The overall performance parameters that are most critical to performance are attenuation and power supply voltages. The attenuation is entirely a function of the attenuator channel module.

### POWER SUPPLIES

Power supply output voltages are adjusted from potentiometers located on the power supplies. See Figure 1-3 for location of these adjustments. Any adjustment should be made using an insulated tuning tool. There is no adjustment for the  $-15V$  supply. Voltage tolerances for the other two outputs are  $+5.3 \pm 0.2V$  and  $+20.3 \pm 0.2V$ .

If power supply voltages are beyond tolerances, and using the tuning adjustment cannot reset it, then it must be determined if the fault is with the power supply or another component. Generally speaking, if the fault is with another component, both power supplies will be affected. However, the best way to determine if the fault is with the power supply is to disconnect the faulted outputs of the supply from the system and then checking the power supply test points with a voltmeter. If the power supply is defective, it should be returned to MITEQ for repair.



**IT IS STRONGLY SUGGESTED THAT ANY MALFUNCTIONING COMPONENT BE  
RETURNED TO MITEQ FOR REPAIR.**

# Index

## B

Beacon Receiver  
  configuring 11  
  general description 1  
  physical 1

## C

Command Codes  
  acquisition range 31  
  backward compatibility mode 32  
  configure from memory 32  
  delta signal level 33  
  Ethernet password 46  
  examples 57  
  external reference 57  
  frequency offset 45  
  IF gain 44  
  IF gain control mode 30  
  input frequency 35  
  internal calendar/clock 33  
  maximum voltage 44  
  measurement mode 42  
  minimum voltage 43  
  model 43  
  output hold time 36  
  output slope 53  
  output voltage 45  
  receiver event log entries 37  
  receiver title 48  
  reference level 46  
  reference voltage 48  
  remote/local control mode 47  
  RF gain 47  
  RF signal level 47  
  set all Ethernet parameters 34  
  signal strength 46  
  signal to noise ratio 53  
  summary 29  
  system fault status 30  
  system voltages 56  
  temperature 54  
  tracking range 55  
  tuner bandwidth 54  
  unit memory register store/recall 39  
  unit memory register store/recall and set 49  
  version 56  
  video bandwidth 55

Controls  
  external 12  
  internal 12

## E

Equipment Characteristics  
  connector wiring information 3  
  functional specifications 5  
  physical 2

ESD 9, 78

Index | 79

## Ethernet Operation

  accessing the system 61  
    via SNMP 70  
    via Telnet 71  
    via the web interface 61  
  firmware upgrade 72  
  setup 58  
    configuring IP operating parameters 59  
    configuring via IPSETUP application 60  
    configuring via serial interface 60  
  connection 58  
  interface 58  
  verifying proper connection and configuration 61

## F

Frequency Compatibility Configuration Procedure  
  backward compatibility 11  
  standard command 11

Front Panel Operations 12  
  keypad operations 13  
    cursor key 13  
    data entry keys 13  
    menu key 13

## I

Installation  
  mounting 9  
  reshipment 9  
  storage 9  
  turn-on procedure 9  
  unpacking 9

## M

Maintenance  
  power supplies 78  
  preventive 78

Major Subassemblies  
  functional description 77  
  power supply 77  
  RF Module 77

## Menus

  acquisition 18  
  alarm 15  
  Ethernet configuration 24  
  IF gain 17  
  main 14  
  memory functions 21  
  output 20  
  receiver revision 26  
  receiver title 25  
  remote interface 23  
  RF gain 17  
  utility 25  
  video bandwidth 19

# Index

## P

### Principles of Operation

- definition of terms 6
  - acquisition range 6
  - delta frequency 6
  - delta level 7
  - gain controls 6
  - holdtime 8
  - IF gain control 7
  - input frequency 6
  - maximum voltage 7
  - minimum voltage 7
  - output slope 8
  - output voltage 7
  - power measurement mode 8
  - reference level 7
  - reference output voltage 7
  - RF gain control 7
  - signal strength 7
  - tracking range 6
  - tuner bandwidth 6
  - video bandwidth 7
- functional description
  - DSP board 74
  - RF module 74

## R

### Remote Operations

- serial remote protocol 27
- serial message format 27

### Revisions ii

## S

### Set Up Guide 73